

# INTERNATIONAL ELECTROTECHNICAL COMMISSION

## IEC 60364-8-1 Edition 2.0 2019-02

### LOW-VOLTAGE ELECTRICAL INSTALLATIONS – Part 8-1: Functional aspects – Energy efficiency

## CORRIGENDUM 1

### 2 Normative references

Replace the reference to IEC 61557-12:2007 with the following new reference:

IEC 61557-12, *Electrical safety in low voltage distribution systems up to 1 000 V AC and 1 500 V DC – Equipment for testing, measuring or monitoring of protective measures – Part 12: Power metering and monitoring devices (PMD)*

### 4.1.3 Design principles

Replace the first dashed list item with the following new item:

– load energy profile (active and reactive energy);

### 8.3.1.2 Requirements on accuracy and measuring range

Table 1

In the first row, second column, replace "IEC 62052-22" with "IEC 62053-22". In the second and third rows, third column, replace "PMD-1", "PMD-2" and "PMD-3" with "PMD-I", "PMD-II" and "PMD-III" respectively, as shown:

Measurement application	Applicable IEC product standards	Device name according to standards	Usual device name	Complementary explanations
Billing (Contractual)	or IEC 62053-21 or IEC 62053-22	Electricity metering equipment	Revenue meter, electricity meter, utility meter	Energy metering for billing applications (e.g. utility invoicing a landlord or a mall owner, sub-billing to tenants)
Energy usage analysis	IEC 61557-12 <sup>a</sup>	Power metering and monitoring device (PMD-I or PMD-II or PMD-III)	Power meter, energy meter	Energy cost and usage analysis (for cost allocation or sub-billing within a company or for energy efficiency purposes)
Power monitoring	IEC 61557-12 <sup>b</sup>	Power metering and monitoring device (PMD-II or PMD-III)	Power meter, energy meter	Demand side power quality analysis and energy cost and usage analysis

Energy estimation		Indicator or sensor	Energy estimator	Devices for giving information needed to correctly operate the energy management system, for example running time of equipment, number of operation, basic measurement
<p><sup>a</sup> Devices used for power quality monitoring, when they provide active energy measurement function, can be used for energy usage analysis.</p> <p><sup>b</sup> Devices used for power quality monitoring in accordance with IEC 62586-1 can be used for power monitoring especially where comparable measurements are needed.</p> <p>NOTE Other information such as occupancy, number of operations, manufacturing figures, is provided by different instruments and are covered by other standards.</p>				

### 8.3.1.3 Measurement

Replace, in the 3 dashed list items, in the third paragraph, "PMD-1", "PMD-2" and "PMD-3" with "PMD-I", "PMD-II" and "PMD-III" respectively.

#### Figure 3

Replace Figure 3, including the Key, with the following new Figure 3 and Key:

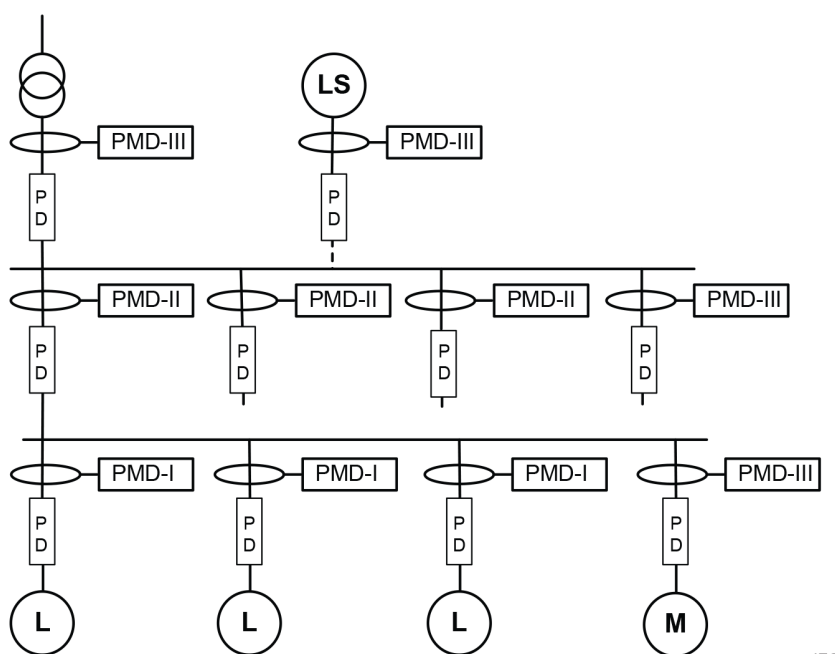

IEC

#### Key

Symbol	Function
<b>PMD</b>	power metering and monitoring device
<b>PMD-I</b>	PMD including at least: $E_a$
<b>PMD-II</b>	PMD including at least: $P, Q, S, E_a, E_r, f, I, U$ and/or $V, PF,$
<b>PMD-III</b>	PMD including at least: $P, Q, S, E_a, E_r, E_{ap}, f, I, I_N, U$ and/or $V, PF, THD_U$ and/or $THD_V$ and/or $THD-R_U$ and/or $THD-R_V, THD_I$ and/or $THD-R_I$
$P$	total active power
$E_a$	total active energy
$Q$	total reactive power
$S$	total apparent power

	$E_r$	total reactive energy
	$E_{ap}$	total apparent energy
	$f$	frequency
	$I$	line current
	$I_N$	neutral current
	$U$	line to line voltage
	$V$	line to neutral voltage
	$PF$	power factor
	$THD_U$	total harmonic distortion voltage related to fundamental
	$THD-R_U$	total harmonic distortion voltage related to RMS value
	$THD_I$	total harmonic current related to fundamental
	$THD-R_I$	total harmonic current related to RMS value
<b>PD</b>		protective device with isolation function
<b>M</b>		motor
<b>L</b>		load
<b>LS</b>		local power supply (e.g. PV, wind turbine, generator) (if present)

Figure 3 – Example of measurement equipment selection in an installation

## 9.1 Methodology

Figure 4

Replace Figure 4 with the following new Figure 4:

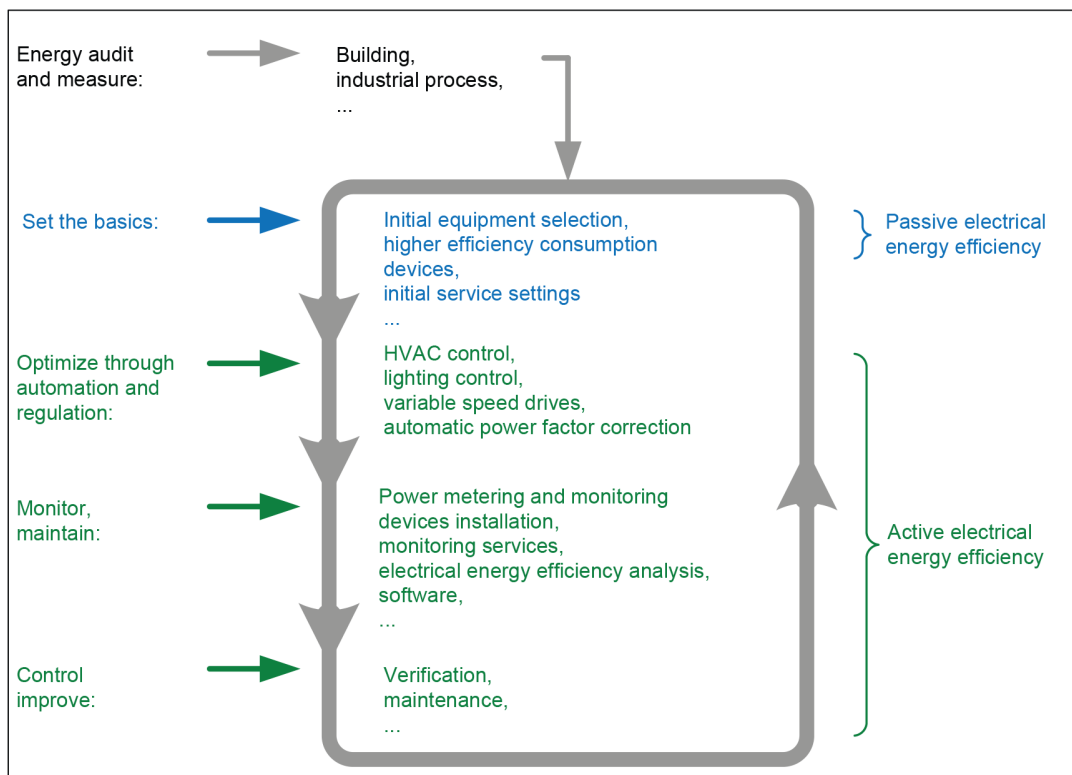

IEC

Figure 4 – Iterative process for electrical energy efficiency management

**B.3.2.2.1 Parameter II01: determination of energy consumption**

**Table B.3**

*In the first column, last row, replace "> 90 %" with "≥ 90 %" as shown:*

**Table B.3 – Determination of energy consumption: coverage**

$K_1$	Points for industrial building	Points for commercial building	Points for infrastructure
< 50 %	0	0	0
≥ 50 % and < 65 %	1	1	1
≥ 65 % and < 75 %	2	2	2
≥ 75 % and < 83 %	4	4	4
≥ 83 % and < 90 %	6	5	6
≥ 90 %	7	6	7

**B.3.2.2.2 Parameter II02: consumption and location of the main substation**

**Table B.4**

*In the first column, last row, replace "> 90 %" with "≥ 90 %" as shown:*

**Table B.4 – Main substation: consumption**

% of consumption vs total consumption	Points for industrial building	Points for commercial building	Points for infrastructure
< 50 %	0	0	0
≥ 50 % and < 70 %	2	1	2
≥ 70 % and < 83 %	4	2	4
≥ 83 % and < 90 %	5	3	5
≥ 90 %	6	4	6

**B.3.2.2.3 Parameter II03: voltage drop**

**Table B.6**

*In the first column, last row, replace "< 1 %" with "≤ 1 %" as shown:*

**Table B.6 – Voltage drop**

$K_{VD}$	Points for industrial building	Points for commercial building	Points for infrastructure
> 5 %	0	0	0
≤ 5 % and > 3 %	1	1	1
≤ 3 % and > 2 %	2	2	2
≤ 2 % and > 1,5 %	4	4	4
≤ 1,5 % and > 1 %	5	5	5
≤ 1 %	6	6	6

**B.3.2.2.5 Parameter II05: efficiency of fixed installed current using equipment**

**Table B.8**

*In the first column, first row, replace "< 1,2" with "≥ 1,2" as shown:*

**Table B.8 – Efficiency of fixed installed current using equipment**

$R_{EC}$	Points for industrial building	Points for commercial building	Points for infrastructure
$\geq 1,2$	0	0	0
$\geq 1,05$ and $< 1,2$	2	2	2
$< 1,05$	4	4	4

**B.3.2.4.3 Parameter MA03: data management**

**Table B.22**

*In the first column, second row, replace "> 1 year" with "≥ 1 year". In the first column, last row, replace "> 5 years" with "≥ 5 years" as shown:*

**Table B.22 – Data management**

Data stored	Points for industrial building	Points for commercial building	Points for infrastructure
< 1 year of history	0	0	0
$\geq 1$ year and $< 5$ years	4	4	4
$\geq 5$ years	10	8	8

**B.3.2.4.4 Parameter MA04: performance of the transformer(s)**

**Table B.23**

*In the first column, first row, replace "> 0,2" with "≥ 0,2" as shown:*

**Table B.23 – Working point of transformer**

$R_{ET}$	Points for industrial building	Points for commercial building	Points for infrastructure
$\geq 0,2$	0	0	0
$< 0,2$	1	1	1

**B.3.3.7 Parameter EM05: measurement by usage**

**Table B.37**

*In the first column, last row, replace "> 4" with "≥ 4" as shown:*

**Table B.37 – Measurement by usage**

Number of usage measured	Points
0	0
$\geq 1$ and $< 2$	4
$\geq 2$ and $< 3$	10
$\geq 3$ and $< 4$	16
$\geq 4$	20