

EUROPEAN STANDARD

EN 1991-4:2006/AC

NORME EUROPÉENNE

November 2012

EUROPÄISCHE NORM

Novembre 2012

November 2012

ICS 91.010.30

English version
Version Française
Deutsche Fassung

Eurocode 1 - Actions on structures - Part 4: Silos and tanks

Eurocode 1 - Actions sur les structures -
Partie 4: Silos et réservoirs

Eurocode 1: Einwirkungen auf Tragwerke -
Teil 4: Einwirkungen auf Silos und
Flüssigkeitsbehälter

This corrigendum becomes effective on 21 November 2012 for incorporation in the three official language versions of the EN.

Ce corrigendum prendra effet le 21 novembre 2012 pour incorporation dans les trois versions linguistiques officielles de la EN.

Die Berichtigung tritt am 21. November 2012 zur Einarbeitung in die drei offiziellen Sprachfassungen der EN in Kraft.



EUROPEAN COMMITTEE FOR STANDARDIZATION
COMITÉ EUROPÉEN DE NORMALISATION
EUROPÄISCHES KOMITEE FÜR NORMUNG

Management Centre: Avenue Marnix 17, B-1000 Brussels

© 2012 CEN All rights of exploitation in any form and by any means reserved worldwide for CEN national Members.
Tous droits d'exploitation sous quelque forme et de quelque manière que ce soit réservés dans le monde entier aux membres nationaux du CEN.
Alle Rechte der Verwertung, gleich in welcher Form und in welchem Verfahren, sind weltweit den nationalen Mitgliedern von CEN vorbehalten.

Ref. No.: EN 1991-4:2006/AC:2012 D/E/F

EN 1991-4:2006/AC:2012 (E)

1 Modifications to 1.2

Replace the following reference:

“EN 1992-4 Eurocode 2: Design of concrete structures: Part 4: Liquid retaining and containment structures”

with the following one:

“EN 1992-3 Eurocode 2: Design of concrete structures: Part 3: Liquid retaining and containment structures”.

Replace the following reference:

“EN 1993-1-6 Eurocode 3: Design of steel structures. General rules: Part 1.6: Supplementary rules for the strength and stability of shell structures”

with the following one:

“EN 1993-1-6 Eurocode 3: Design of steel structures. Part 1-6: Strength and Stability of Shell Structures”.

2 Modification to 2.5

Replace Paragraph (3) with the following one:

“(3) A higher Action Assessment Class than that required in 2.5 (2), as described in 2.5 (5), Table 2.1, may always be adopted. Any part of the procedures for a higher Action Assessment Class may be adopted whenever it is appropriate.”.

3 Modification to 5.2.1.1

In Figure 5.2, in Key 1, replace “ z_0 ” with “ z_0 ”.

4 Modification to 5.2.2.2

In Paragraph (5), replace Formula (5.28) with:

“

$$C_{pe} = 0,42 C_{op} [1+2E^2] (1 - e^{\{-1,5 [(h_e/d_e)^{-1}] - 1\}}) \dots (5.28)”.$$

5 Modification to 5.2.2.3

In Paragraph (2), Figure 5.4, in Key 1, replace “ z_0 ” with “ z_0 ”.

6 Modification to 6.1.2

In Paragraph (7), in Formula (6.7), delete “.” before “ γ ” in the first bracket as follows:

$$p_v = \left(\frac{\gamma_h}{n-1} \right) \left\{ \left(\frac{x}{h_h} \right) - \left(\frac{x}{h_h} \right)^n \right\} + p_{vft} \left(\frac{x}{h_h} \right)^n.$$

7 Modification to C.6.1

Replace the whole Figure C.1 with the following figure and text:

“

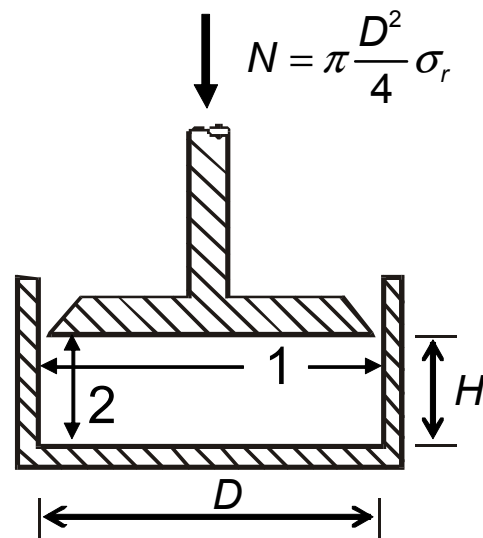

Key

- 1 Smooth surfaces
- 2 Rough surfaces

Figure C.1: Device for the determination of γ .

8 Modification to C.7.3

Replace the whole Figure C.2 with the following figure and text:

“

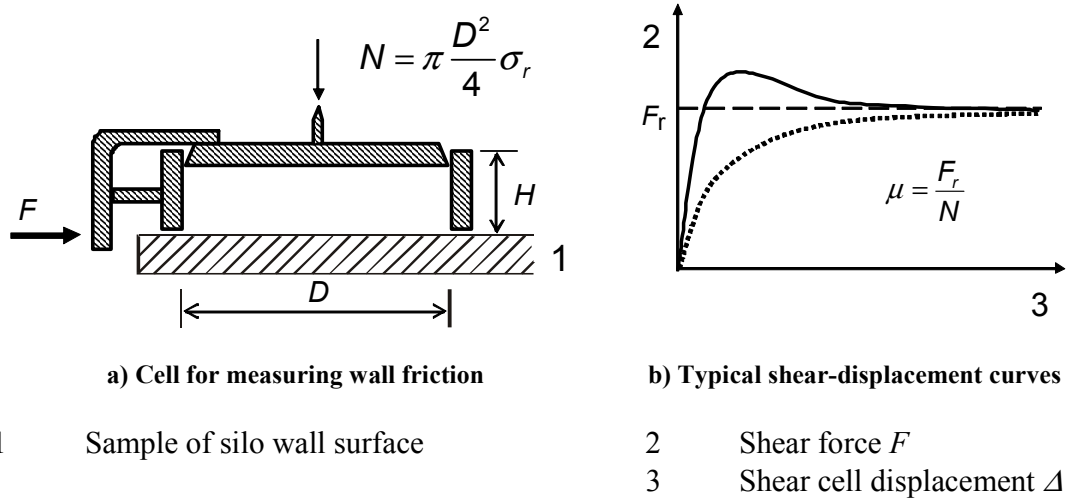

Figure C.2: Test method for determination of wall friction coefficient μ ".

9 Modification to C.8.1.1

Replace the whole Figure C.3 with the following figure and text:

“

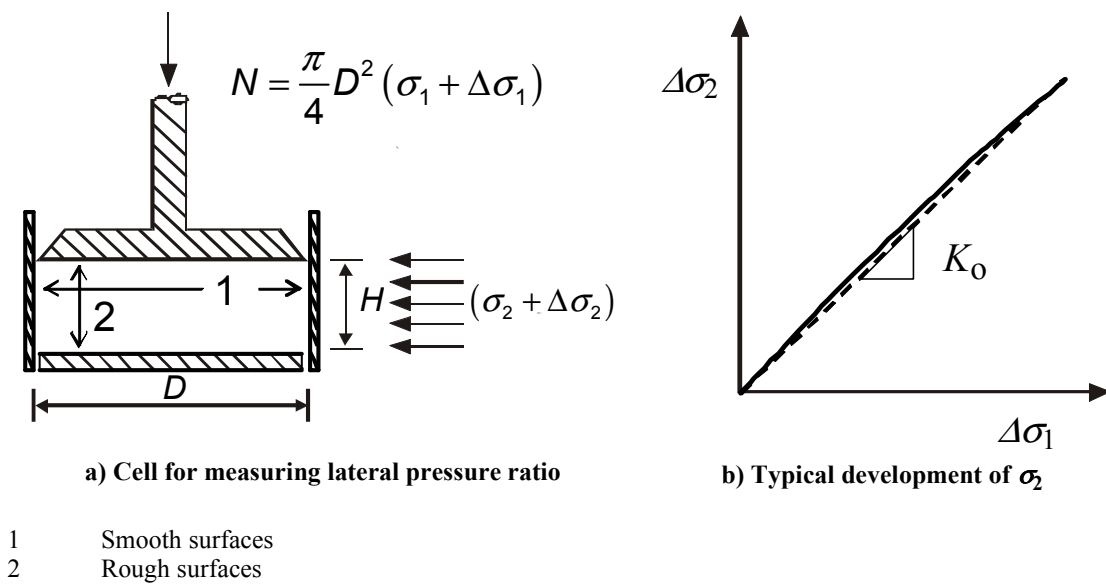

Figure C.3: Test method for determining lateral pressure ratio K_0 ".

10 Modification to C.9.1.3

In Paragraph (6), delete the bracket at the end of the last sentence as follows:

“Stresses determined from the two tests are named in Table C.1.”.