



**INTERNATIONAL STANDARD ISO 13849-1:2006**  
**TECHNICAL CORRIGENDUM 1**

Published 2009-02-15

INTERNATIONAL ORGANIZATION FOR STANDARDIZATION • МЕЖДУНАРОДНАЯ ОРГАНИЗАЦИЯ ПО СТАНДАРТИЗАЦИИ • ORGANISATION INTERNATIONALE DE NORMALISATION

**Safety of machinery — Safety-related parts of control systems —**

**Part 1:**  
**General principles for design**

TECHNICAL CORRIGENDUM 1

*Sécurité des machines — Parties des systèmes de commande relatives à la sécurité —*

*Partie 1: Principes généraux de conception*

*RECTIFICATIF TECHNIQUE 1*

Technical Corrigendum 1 to ISO 13849-1:2006 was prepared by Technical Committee ISO/TC 199, *Safety of machinery*.

Page 37, Figure 12

Replace the drawing showing the designated architecture for category 4 with the following drawing. This corrects the arrowed lines labeled “m” between L1 and O1, and L2 and O2, by changing them from dashed to solid lines, representing higher diagnostic coverage.

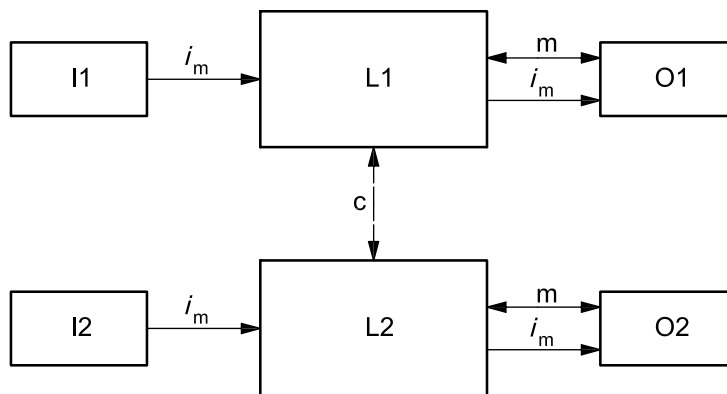

Page 44, A.2.2

Correct the heading of this subclause to read “Frequency and/or exposure times to hazard, F1 and F2”.

Page 62, F.2

Delete the final paragraph prior to Table F.1. This made reference to a “Table F.2” that was incorporated into Table F.1 and did not appear in the final published version of the standard.