

INTERNATIONAL STANDARD

NORME INTERNATIONALE

**Medical electrical equipment –
Part 2-52: Particular requirements for the basic safety and essential performance
of medical beds**

**Appareils électromédicaux –
Partie 2-52: Exigences particulières de sécurité de base et de performances
essentiels des lits médicaux**



THIS PUBLICATION IS COPYRIGHT PROTECTED

Copyright © 2009 IEC, Geneva, Switzerland

All rights reserved. Unless otherwise specified, no part of this publication may be reproduced or utilized in any form or by any means, electronic or mechanical, including photocopying and microfilm, without permission in writing from either IEC or IEC's member National Committee in the country of the requester.

If you have any questions about IEC copyright or have an enquiry about obtaining additional rights to this publication, please contact the address below or your local IEC member National Committee for further information.

Droits de reproduction réservés. Sauf indication contraire, aucune partie de cette publication ne peut être reproduite ni utilisée sous quelque forme que ce soit et par aucun procédé, électronique ou mécanique, y compris la photocopie et les microfilms, sans l'accord écrit de la CEI ou du Comité national de la CEI du pays du demandeur.

Si vous avez des questions sur le copyright de la CEI ou si vous désirez obtenir des droits supplémentaires sur cette publication, utilisez les coordonnées ci-après ou contactez le Comité national de la CEI de votre pays de résidence.

IEC Central Office
3, rue de Varembe
CH-1211 Geneva 20
Switzerland
Email: inmail@iec.ch
Web: www.iec.ch

About the IEC

The International Electrotechnical Commission (IEC) is the leading global organization that prepares and publishes International Standards for all electrical, electronic and related technologies.

About IEC publications

The technical content of IEC publications is kept under constant review by the IEC. Please make sure that you have the latest edition, a corrigenda or an amendment might have been published.

- Catalogue of IEC publications: www.iec.ch/searchpub

The IEC on-line Catalogue enables you to search by a variety of criteria (reference number, text, technical committee,...). It also gives information on projects, withdrawn and replaced publications.

- IEC Just Published: www.iec.ch/online_news/justpub

Stay up to date on all new IEC publications. Just Published details twice a month all new publications released. Available on-line and also by email.

- Electropedia: www.electropedia.org

The world's leading online dictionary of electronic and electrical terms containing more than 20 000 terms and definitions in English and French, with equivalent terms in additional languages. Also known as the International Electrotechnical Vocabulary online.

- Customer Service Centre: www.iec.ch/webstore/custserv

If you wish to give us your feedback on this publication or need further assistance, please visit the Customer Service Centre FAQ or contact us:

Email: csc@iec.ch
Tel.: +41 22 919 02 11
Fax: +41 22 919 03 00

A propos de la CEI

La Commission Electrotechnique Internationale (CEI) est la première organisation mondiale qui élabore et publie des normes internationales pour tout ce qui a trait à l'électricité, à l'électronique et aux technologies apparentées.

A propos des publications CEI

Le contenu technique des publications de la CEI est constamment revu. Veuillez vous assurer que vous possédez l'édition la plus récente, un corrigendum ou amendement peut avoir été publié.

- Catalogue des publications de la CEI: www.iec.ch/searchpub/cur_fut-f.htm

Le Catalogue en-ligne de la CEI vous permet d'effectuer des recherches en utilisant différents critères (numéro de référence, texte, comité d'études,...). Il donne aussi des informations sur les projets et les publications retirées ou remplacées.

- Just Published CEI: www.iec.ch/online_news/justpub

Restez informé sur les nouvelles publications de la CEI. Just Published détaille deux fois par mois les nouvelles publications parues. Disponible en-ligne et aussi par email.

- Electropedia: www.electropedia.org

Le premier dictionnaire en ligne au monde de termes électroniques et électriques. Il contient plus de 20 000 termes et définitions en anglais et en français, ainsi que les termes équivalents dans les langues additionnelles. Egalement appelé Vocabulaire Electrotechnique International en ligne.

- Service Clients: www.iec.ch/webstore/custserv/custserv_entry-f.htm

Si vous désirez nous donner des commentaires sur cette publication ou si vous avez des questions, visitez le FAQ du Service clients ou contactez-nous:

Email: csc@iec.ch
Tél.: +41 22 919 02 11
Fax: +41 22 919 03 00

INTERNATIONAL STANDARD

NORME INTERNATIONALE

**Medical electrical equipment –
Part 2-52: Particular requirements for the basic safety and essential performance
of medical beds**

**Appareils électromédicaux –
Partie 2-52: Exigences particulières de sécurité de base et de performances
essentiels des lits médicaux**

INTERNATIONAL
ELECTROTECHNICAL
COMMISSION

COMMISSION
ELECTROTECHNIQUE
INTERNATIONALE

PRICE CODE
CODE PRIX

XC

CONTENTS

FOREWORD.....	5
INTRODUCTION.....	7
201.1 Scope, object and related standards	8
201.2 Normative references.....	9
201.3 Terms and definitions.....	10
201.4 General requirements	13
201.5 General requirements for testing of ME EQUIPMENT	13
201.6 Classification of ME EQUIPMENT and ME SYSTEMS.....	15
201.7 ME EQUIPMENT identification, marking and documents	15
201.8 Protection against electrical HAZARDS from ME EQUIPMENT	20
201.9 Protection against MECHANICAL HAZARDS of ME EQUIPMENT and ME SYSTEMS	21
201.10 Protection against unwanted and excessive radiation HAZARDS	44
201.11 Protection against excessive temperatures and other HAZARDS	44
201.12 Accuracy of controls and instruments and protection against hazardous outputs	46
201.13 HAZARDOUS SITUATIONS and fault conditions	47
201.14 PROGRAMMABLE ELECTRICAL MEDICAL SYSTEMS (PEMS).....	47
201.15 Construction of ME EQUIPMENT.....	48
201.16 ME SYSTEMS	51
201.17 Electromagnetic compatibility of ME EQUIPMENT and ME SYSTEMS	51
Annexes	51
Annex AA (informative) Particular guidance and rationale.....	52
Annex BB (normative) Design requirements and recommendations for MEDICAL BEDS.....	67
Annex CC (informative) Particular guidance for assessing risk of entrapment in v-shaped openings	75
Bibliography.....	81
Index of defined terms used in this particular standard.....	82
Figure 201.101 – APPLIED PART.....	10
Figure 201.102 – MEDICAL BED, general arrangement (example, schematic presentation only)	12
Figure 201.103a – Cone tool.....	14
Figure 201.103b – Cylinder tool	14
Figure 201.103 – Entrapment test tools.....	14
Figure 201.104 – Loading pad	15
Figure 201.105 – Graphic symbol for maximum PATIENT weight and SAFE WORKING LOAD	16
Figure 201.106 – MEDICAL BED function controls and/or actuators: guidelines for creating graphic symbols	18
Figure 201.107 – Example of MEDICAL BED with segmented or split SIDE RAIL	22
Figure 201.108 – Example of MEDICAL BED with single piece SIDE RAIL	23
Figure 201.109 – Allowable spacing for fingers in areas of normal reach around the perimeter of the MATTRESS SUPPORT PLATFORM	28

Figure 201.110 – Example using barriers for clearance measurement around the perimeter of the MATTRESS SUPPORT PLATFORM to mitigate PATIENT-finger entrapment	29
Figure 201.111a – Foot and toe clearance area between moving parts and the floor.....	29
Figure 201.111b – Toe clearance area between moving parts and the floor	30
Figure 201.111 – Clearance areas	30
Figure 201.112 – Lateral stability test along the side of the MEDICAL BED.....	32
Figure 201.113 – Longitudinal stability test with removable FOOT BOARD	32
Figure 201.114 – Longitudinal stability test with fixed HEAD/FOOT BOARDS.....	33
Figure 201.115 – Distribution of SAFE WORKING LOAD for tests.....	37
Figure 201.116 – Position of loading pad (see Figure 201.104).....	40
Figure 201.117 – Application of forces for test of SIDE RAIL.....	42
Figure 201.118 – Height of SIDE RAIL	43
Figure 201.119a – Angle γ between the back section and the leg section of the MATTRESS SUPPORT PLATFORM.....	49
Figure 201.119b – Angle γ between the back section and the upper leg section of the MATTRESS SUPPORT PLATFORM.....	49
Figure 201.119c – Angle γ between the angled back section and upper leg section of the MATTRESS SUPPORT PLATFORM	49
Figure 201.119d – Angle γ between the angled back section and the leg/upper leg section of the MATTRESS SUPPORT PLATFORM	50
Figure 201.119 – Configurations of the MATTRESS SUPPORT PLATFORM	50
Figure AA.1 – Marking to select recommended mattresses specified by the MANUFACTURER.....	54
Figure AA.2 – Marking for detachable SIDE RAILS specified by the MANUFACTURER	54
Figure AA.3 – Resultant forces without mattress	58
Figure AA.4 – Resultant forces with mattress.....	58
Figure AA.5 – Example of 60 mm gap measurement of B.....	58
Figure AA.6 – Angle measurement example of B	58
Figure AA.7 – Placement of measurement TOOL for measurement of D	59
Figure AA.8 – Example of area D measurement that passes	59
Figure AA.9 – Example of area D measurement that fails.....	59
Figure AA.10 – Example of area D measurement that fails (on limit)	60
Figure AA.11 – Example of potential PATIENT entrapment in area A within the SIDE RAIL	60
Figure AA.12 – Example of potential PATIENT entrapment in area A below the SIDE RAIL	60
Figure AA.13 – Example of potential PATIENT entrapment in area B.....	60
Figure AA.14 – Example of potential PATIENT entrapment in area C between split SIDE RAIL	60
Figure AA.15 – Example of potential PATIENT entrapment in area C between SIDE RAIL and HEAD BOARD	61
Figure AA.16 – Example of potential PATIENT entrapment in area D.....	61
Figure AA.17 – Example of potential PATIENT entrapment in area A below a single piece SIDE RAIL	61
Figure BB.1 – Other areas of possible impact testing.....	68
Figure BB.2 – Impactor	69
Figure BB.3 – Schematic presentation of under MEDICAL BED clearance.....	72

Figure BB.4 – Recommendations and requirements regarding angles for different sections of the MATTRESS SUPPORT PLATFORM	74
Figure CC.1 – Wedge tool.....	76
Figure CC.2 – V-shaped opening in relation to B.....	77
Figure CC.3 – Pass/fail in relation to area B	77
Figure CC.4 – Positioning of wedge tool	78
Figure CC.5 – Pass/fail in relation to area C between HEAD BOARD and FOOT BOARD.....	79
Figure CC.6 – Pass/fail in relation to area C between split SIDE RAILS	80
Table 201.101 – Protection against PATIENT entrapment	24
Table 201.102 – Protection against inadvertent PATIENT falls	44
Table 24 – Allowable maximum temperatures for skin contact with MEDICAL BED APPLIED PARTS.....	45
Table BB.1 – Normative and informative requirements for different APPLICATION ENVIRONMENTS 1 to 5	67

This document is a preview generated by EVS

INTERNATIONAL ELECTROTECHNICAL COMMISSION

MEDICAL ELECTRICAL EQUIPMENT –

**Part 2-52: Particular requirements for the basic safety
and essential performance of medical beds**

FOREWORD

- 1) The International Electrotechnical Commission (IEC) is a worldwide organization for standardization comprising all national electrotechnical committees (IEC National Committees). The object of IEC is to promote international co-operation on all questions concerning standardization in the electrical and electronic fields. To this end and in addition to other activities, IEC publishes International Standards, Technical Specifications, Technical Reports, Publicly Available Specifications (PAS) and Guides (hereafter referred to as "IEC Publication(s)"). Their preparation is entrusted to technical committees; any IEC National Committee interested in the subject dealt with may participate in this preparatory work. International, governmental and non-governmental organizations liaising with the IEC also participate in this preparation. IEC collaborates closely with the International Organization for Standardization (ISO) in accordance with conditions determined by agreement between the two organizations.
- 2) The formal decisions or agreements of IEC on technical matters express, as nearly as possible, an international consensus of opinion on the relevant subjects since each technical committee has representation from all interested IEC National Committees.
- 3) IEC Publications have the form of recommendations for international use and are accepted by IEC National Committees in that sense. While all reasonable efforts are made to ensure that the technical content of IEC Publications is accurate, IEC cannot be held responsible for the way in which they are used or for any misinterpretation by any end user.
- 4) In order to promote international uniformity, IEC National Committees undertake to apply IEC Publications transparently to the maximum extent possible in their national and regional publications. Any divergence between any IEC Publication and the corresponding national or regional publication shall be clearly indicated in the latter.
- 5) IEC itself does not provide any attestation of conformity. Independent certification bodies provide conformity assessment services and, in some areas, access to IEC marks of conformity. IEC is not responsible for any services carried out by independent certification bodies.
- 6) All users should ensure that they have the latest edition of this publication.
- 7) No liability shall attach to IEC or its directors, employees, servants or agents including individual experts and members of its technical committees and IEC National Committees for any personal injury, property damage or other damage of any nature whatsoever, whether direct or indirect, or for costs (including legal fees) and expenses arising out of the publication, use of, or reliance upon, this IEC Publication or any other IEC Publications.
- 8) Attention is drawn to the Normative references cited in this publication. Use of the referenced publications is indispensable for the correct application of this publication.
- 9) Attention is drawn to the possibility that some of the elements of this IEC Publication may be the subject of patent rights. IEC shall not be held responsible for identifying any or all such patent rights.

International standard IEC 60601-2-52 has been prepared by IEC subcommittee 62D: Electromedical equipment, of IEC technical committee 62: Electrical equipment in medical practice, and by ISO technical committee 173: Assistive products for persons with disability.

It is published as double logo standard.

This first edition cancels and replaces the first edition of IEC 60601-2-38, published in 1996, and its Amendment 1 (1999). This edition constitutes a technical revision.

The text of this particular standard is based on the following documents:

FDIS	Report on voting
62D/795/FDIS	62D/815/RVD

Full information on the voting for the approval of this particular standard can be found in the report on voting indicated in the above table. In ISO, the standard has been approved by 20 P-members out of 20 having cast a vote.

This publication has been drafted in accordance with the ISO/IEC Directives, Part 2.

In this standard, the following print types are used:

- Requirements and definitions: roman type.
- *Test specifications: italic type.*
- Informative material appearing outside of tables, such as notes, examples and references: in smaller type. Normative text of tables is also in a smaller type.
- TERMS DEFINED IN CLAUSE 3 OF THE GENERAL STANDARD, IN THIS PARTICULAR STANDARD OR AS NOTED: SMALL CAPITALS.

In referring to the structure of this standard, the term

- “clause” means one of the seventeen numbered divisions within the table of contents, inclusive of all subdivisions (e.g. Clause 7 includes subclauses 7.1, 7.2, etc.);
- “subclause” means a numbered subdivision of a clause (e.g. 7.1, 7.2 and 7.2.1 are all subclauses of Clause 7).

References to clauses within this standard are preceded by the term “Clause” followed by the clause number. References to subclauses within this collateral standard are by number only.

In this standard, the conjunctive “or” is used as an “inclusive or” so a statement is true if any combination of the conditions is true.

The verbal forms used in this standard conform to usage described in Annex H of the ISO/IEC Directives, Part 2. For the purposes of this standard, the auxiliary verb:

- “shall” means that compliance with a requirement or a test is mandatory for compliance with this standard;
- “should” means that compliance with a requirement or a test is recommended but is not mandatory for compliance with this standard;
- “may” is used to describe a permissible way to achieve compliance with a requirement or test.

An asterisk (*) as the first character of a title or at the beginning of a paragraph or table title indicates that there is guidance or rationale related to that item in Annex AA.

A list of all parts of the IEC 60601 series, published under the general title *Medical electrical equipment*, can be found on the IEC website.

The committee has decided that the contents of this publication will remain unchanged until the maintenance result date indicated on the IEC web site under "<http://webstore.iec.ch>" in the data related to the specific publication. At this date, the publication will be

- reconfirmed,
- withdrawn,
- replaced by a revised edition, or
- amended.

INTRODUCTION

In 1996, the IEC published the first edition of the particular standard for electrically operated hospital beds, IEC 60601-2-38. The publication was in response to demand in the field for a universal standard addressing HAZARDS specific to the safety of the hospital bed. Used in conjunction with a MANUFACTURER'S RISK ASSESSMENT, the standard was felt to be the current thinking on establishing a basic safety benchmark for industry.

An amendment of IEC 60601-2-38 issued in 1999 recognized the need to mitigate against a RISK of PATIENT entrapment in the SIDE RAILS, again combined with the use of the MANUFACTURER'S RISK ASSESSMENT. Although this improved the particular standard, it still was centered upon electrically operated hospital beds, and failed to take into account manually operated hospital beds and products in other medical environments.

In 2000, the EN 1970 standard (*Adjustable beds for DISABLED PERSONS – Requirements and test methods*) was published, which addressed beds used by DISABLED PERSONS to alleviate or compensate for a disability or handicap. This standard offered a broadened scope in conjunction with IEC 60601-2-38, but after the edition of Amendment 1 to IEC 60601-2-38, the opportunity presented itself to combine the two standards to a common, international standard.

As work began on the integration, the IEC adjusted its stance on BASIC SAFETY and ESSENTIAL PERFORMANCE, integrating them into the third edition of IEC 60601-1. It therefore became necessary to align the new standard with the third edition. The particular standard was given a new number, IEC 60601-2-52, and work began on alignment to third edition.

This particular standard, therefore, is the realization of much work in alignment, and scope adjustment between IEC 60601-2-38, EN 1970, and the third edition of IEC 60601-1. It represents the current thinking in BASIC SAFETY and ESSENTIAL PERFORMANCE of the MEDICAL BED as used to alleviate illness of PATIENTS and disability of DISABLED PERSONS. This is the effort of a joint working group of the IEC and the ISO.

generated by EVS

MEDICAL ELECTRICAL EQUIPMENT –

Part 2-52: Particular requirements for the basic safety and essential performance of medical beds

201.1 Scope, object and related standards

Clause 1 of the general standard¹⁾ applies, except as follows:

201.1.1 * Scope

Replacement:

This International Standard applies to the BASIC SAFETY and ESSENTIAL PERFORMANCE of MEDICAL BEDS intended for adults, hereafter referred to as MEDICAL BED as defined in 201.3.212.

If a clause or subclause is specifically intended to be applicable to a MEDICAL BED only, or to ME SYSTEMS only, the title and content of that clause or subclause will say so. If that is not the case, the clause or subclause applies both to MEDICAL BED and to ME SYSTEMS, as relevant.

HAZARDS inherent in the intended physiological function of MEDICAL BED or ME SYSTEMS within the scope of this standard are not covered by specific requirements in this standard except in 7.2.13 and 8.4.1 of the general standard.

NOTE See also 4.2 of the General Standard.

201.1.2 Object

Replacement:

The object of this particular standard is to establish particular BASIC SAFETY and ESSENTIAL PERFORMANCE requirements for MEDICAL BEDS as defined in 201.3.212.

201.1.3 Collateral standards

Addition:

This particular standard refers to those applicable collateral standards that are listed in Clause 2 of the general standard and Clause 2 of this particular standard.

IEC 60601-1-3, IEC 60601-1-8 and IEC 60601-1-10²⁾ do not apply. All other published collateral standards in the IEC 60601-1 series apply as published.

¹⁾ The general standard is IEC 60601-1:2005, *Medical electrical equipment – Part 1: General requirements for basic safety and essential performance*.

²⁾ IEC 60601-1-10:2007, *Medical electrical equipment – Part 1-10: General requirements for basic safety and essential performance – Collateral Standard: Requirements for the development of physiologic closed-loop controllers*

201.1.4 Particular standards

Replacement:

In the IEC 60601 series, particular standards may modify, replace or delete requirements contained in the general standard and collateral standards as appropriate for the particular ME EQUIPMENT under consideration, and may add other BASIC SAFETY and ESSENTIAL PERFORMANCE requirements.

A requirement of a particular standard takes priority over the general standard.

For brevity, IEC 60601-1 is referred to in this particular standard as the general standard. Collateral standards are referred to by their document number.

The numbering of clauses and subclauses of this particular standard corresponds to that of the general standard with the prefix "201" (e.g. 201.1 in this standard addresses the content of Clause 1 of the general standard) or applicable collateral standard with the prefix "20x" where x is the final digit(s) of the collateral standard document number (e.g. 202.4 in this particular standard addresses the content of Clause 4 of the IEC 60601-1-2 collateral standard, 203.4 in this particular standard addresses the content of Clause 4 of the IEC 60601-1-3 collateral standard, etc.). The changes to the text of the general standard are specified by the use of the following words:

"Replacement" means that the clause or subclause of the general standard or applicable collateral standard is replaced completely by the text of this particular standard.

"Addition" means that the text of this particular standard is additional to the requirements of the general standard or applicable collateral standard.

"Amendment" means that the clause or subclause of the general standard or applicable collateral standard is amended as indicated by the text of this particular standard.

Subclauses, figures or tables which are additional to those of the general standard are numbered starting from 201.101. However, due to the fact that definitions in the general standard are numbered 3.1 through 3.139, additional definitions in this standard are numbered beginning from 201.3.201. Additional annexes are lettered AA, BB, etc., and additional items aa), bb), etc.

Subclauses, figures or tables which are additional to those of a collateral standard are numbered starting from 20x, where "x" is the number of the collateral standard, e.g. 202 for IEC 60601-1-2, 203 for IEC 60601-1-3, etc.

The term "this standard" is used to make reference to the general standard, any applicable collateral standards and this particular standard taken together.

Where there is no corresponding clause or subclause in this particular standard, the clause or subclause of the general standard or applicable collateral standard, although possibly not relevant, applies without modification; where it is intended that any part of the general standard or applicable collateral standard, although possibly relevant, is not to be applied, a statement to that effect is given in this particular standard.

201.2 Normative references

NOTE Informative references are listed in the bibliography on page 81.

Clause 2 of the general standard applies except as follows:

Addition:

IEC 60068-2-31:2008, *Environmental testing – Part 2-31: Tests – Test Ec: Rough handling shocks, primarily for equipment-type specimens*

201.3 Terms and definitions

For the purposes of this document, the terms and definitions given in IEC 60601-1:2005 apply, except as follows:

NOTE An index of defined terms is found beginning on page 82.

201.3.8 APPLIED PART

Addition:

The APPLIED PART includes all parts of the MEDICAL BED that are within reach of the PATIENT, even if they are underneath the MATTRESS SUPPORT SURFACE (see Figure 201.101)

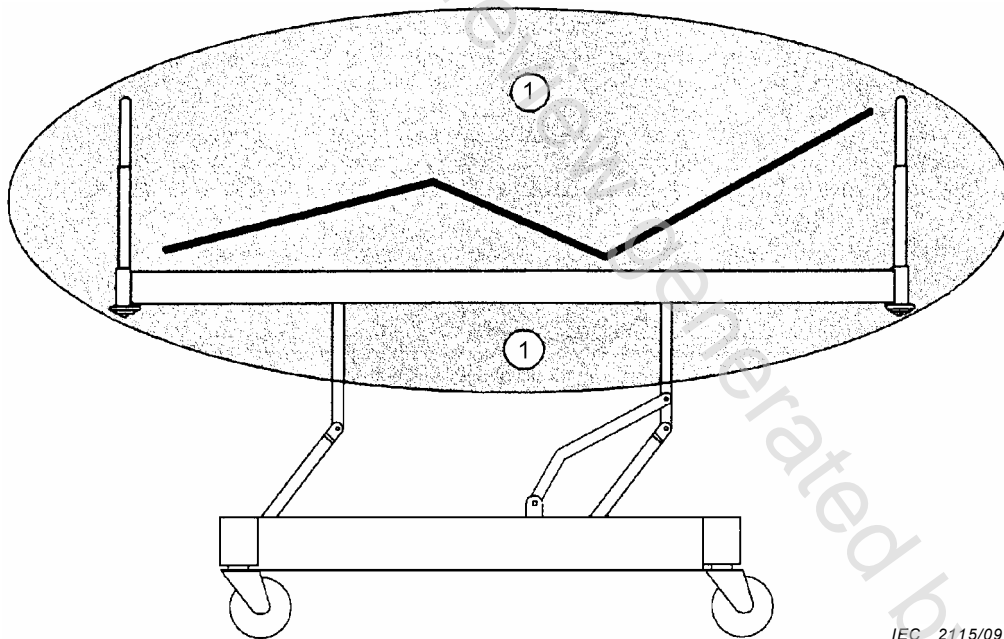

Key

- 1 Region of APPLIED PART including ACCESSORIES

Figure 201.101 – APPLIED PART

201.3.76 PATIENT

Replacement:

person undergoing a medical procedure or DISABLED PERSON