

INTERNATIONAL STANDARD

NORME INTERNATIONALE

**Low voltage surge protective devices –
Part 21: Surge protective devices connected to telecommunications and
signalling networks – Performance requirements and testing methods**

**Parafoudres basse tension –
Partie 21: Parafoudres connectés aux réseaux de signaux et de
télécommunications – Prescriptions de fonctionnement et méthodes d'essais**



THIS PUBLICATION IS COPYRIGHT PROTECTED

Copyright © 2009 IEC, Geneva, Switzerland

All rights reserved. Unless otherwise specified, no part of this publication may be reproduced or utilized in any form or by any means, electronic or mechanical, including photocopying and microfilm, without permission in writing from either IEC or IEC's member National Committee in the country of the requester.

If you have any questions about IEC copyright or have an enquiry about obtaining additional rights to this publication, please contact the address below or your local IEC member National Committee for further information.

Droits de reproduction réservés. Sauf indication contraire, aucune partie de cette publication ne peut être reproduite ni utilisée sous quelque forme que ce soit et par aucun procédé, électronique ou mécanique, y compris la photocopie et les microfilms, sans l'accord écrit de la CEI ou du Comité national de la CEI du pays du demandeur.

Si vous avez des questions sur le copyright de la CEI ou si vous désirez obtenir des droits supplémentaires sur cette publication, utilisez les coordonnées ci-après ou contactez le Comité national de la CEI de votre pays de résidence.

IEC Central Office
3, rue de Varembe
CH-1211 Geneva 20
Switzerland
Email: inmail@iec.ch
Web: www.iec.ch

About the IEC

The International Electrotechnical Commission (IEC) is the leading global organization that prepares and publishes International Standards for all electrical, electronic and related technologies.

About IEC publications

The technical content of IEC publications is kept under constant review by the IEC. Please make sure that you have the latest edition, a corrigenda or an amendment might have been published.

- Catalogue of IEC publications: www.iec.ch/searchpub

The IEC on-line Catalogue enables you to search by a variety of criteria (reference number, text, technical committee,...). It also gives information on projects, withdrawn and replaced publications.

- IEC Just Published: www.iec.ch/online_news/justpub

Stay up to date on all new IEC publications. Just Published details twice a month all new publications released. Available on-line and also by email.

- Electropedia: www.electropedia.org

The world's leading online dictionary of electronic and electrical terms containing more than 20 000 terms and definitions in English and French, with equivalent terms in additional languages. Also known as the International Electrotechnical Vocabulary online.

- Customer Service Centre: www.iec.ch/webstore/custserv

If you wish to give us your feedback on this publication or need further assistance, please visit the Customer Service Centre FAQ or contact us:

Email: csc@iec.ch
Tel.: +41 22 919 02 11
Fax: +41 22 919 03 00

A propos de la CEI

La Commission Electrotechnique Internationale (CEI) est la première organisation mondiale qui élabore et publie des normes internationales pour tout ce qui a trait à l'électricité, à l'électronique et aux technologies apparentées.

A propos des publications CEI

Le contenu technique des publications de la CEI est constamment revu. Veuillez vous assurer que vous possédez l'édition la plus récente, un corrigendum ou amendement peut avoir été publié.

- Catalogue des publications de la CEI: www.iec.ch/searchpub/cur_fut-f.htm

Le Catalogue en-ligne de la CEI vous permet d'effectuer des recherches en utilisant différents critères (numéro de référence, texte, comité d'études,...). Il donne aussi des informations sur les projets et les publications retirées ou remplacées.

- Just Published CEI: www.iec.ch/online_news/justpub

Restez informé sur les nouvelles publications de la CEI. Just Published détaille deux fois par mois les nouvelles publications parues. Disponible en-ligne et aussi par email.

- Electropedia: www.electropedia.org

Le premier dictionnaire en ligne au monde de termes électroniques et électriques. Il contient plus de 20 000 termes et définitions en anglais et en français, ainsi que les termes équivalents dans les langues additionnelles. Egalement appelé Vocabulaire Electrotechnique International en ligne.

- Service Clients: www.iec.ch/webstore/custserv/custserv_entry-f.htm

Si vous désirez nous donner des commentaires sur cette publication ou si vous avez des questions, visitez le FAQ du Service clients ou contactez-nous:

Email: csc@iec.ch
Tél.: +41 22 919 02 11
Fax: +41 22 919 03 00

INTERNATIONAL STANDARD

NORME INTERNATIONALE

**Low voltage surge protective devices –
Part 21: Surge protective devices connected to telecommunications and
signalling networks – Performance requirements and testing methods**

**Parafoudres basse tension –
Partie 21: Parafoudres connectés aux réseaux de signaux et de
télécommunications – Prescriptions de fonctionnement et méthodes d'essais**

INTERNATIONAL
ELECTROTECHNICAL
COMMISSION

COMMISSION
ELECTROTECHNIQUE
INTERNATIONALE

CONTENTS

FOREWORD.....	5
INTRODUCTION.....	7
1 General.....	8
1.1 Scope.....	8
1.2 SPD configurations.....	8
1.3 Use of this standard.....	10
2 Normative references.....	13
3 Definitions.....	14
4 Service and test conditions.....	17
4.1 Service conditions.....	17
4.1.1 Normal service conditions.....	17
4.1.2 Abnormal service conditions.....	18
4.2 Test temperature and humidity.....	18
4.3 SPD testing.....	18
4.4 Waveform tolerances.....	19
5 Requirements.....	19
5.1 General requirements.....	19
5.1.1 Identification and documentation.....	19
5.1.2 Marking.....	19
5.2 Electrical requirements.....	20
5.2.1 Voltage-limiting requirements.....	20
5.2.2 Current-limiting requirements.....	21
5.2.3 Transmission requirements.....	22
5.3 Mechanical requirements.....	22
5.3.1 Terminals and connectors.....	23
5.3.2 Mechanical strength (mounting).....	24
5.3.3 Resistance to ingress of solid objects and to harmful ingress of water.....	24
5.3.4 Protection against direct contact.....	24
5.3.5 Fire resistance.....	24
5.4 Environmental requirements.....	24
5.4.1 High temperature and humidity endurance.....	24
5.4.2 Environmental cycling with impulse surges.....	25
5.4.3 Environmental cycling with a.c. surges.....	25
6 Type test.....	25
6.1 General tests.....	25
6.1.1 Identification and documentation.....	25
6.1.2 Marking.....	25
6.2 Electrical tests.....	26
6.2.1 Voltage-limiting tests.....	26
6.2.2 Current-limiting tests.....	32
6.2.3 Transmission tests.....	35
6.3 Mechanical tests.....	37
6.3.1 Terminals and connectors.....	37
6.3.2 Mechanical strength (mounting).....	39
6.3.3 Resistance to ingress of solid objects and to harmful ingress of water.....	39
6.3.4 Protection against direct contact.....	39

6.3.5	Fire resistance.....	40
6.4	Environmental tests.....	41
6.4.1	High temperature and humidity endurance.....	41
6.4.2	Environmental cycling with impulse surges.....	41
6.4.3	Environmental cycling with a.c. surges.....	42
6.5	Acceptance tests.....	42
Annex A (informative) Devices with current-limiting components only.....		56
Annex B (Void).....		57
Annex C (Void).....		58
Annex D (informative) Measurement accuracy.....		59
Annex E (informative) Determination of let-through current (I_p).....		60
Bibliography.....		63
Figure 1 – SPD configurations.....		9
Figure 16 – Examples of multi-line SPDs with a common protective element.....		28
Figure 2 – Test circuits for impulse reset time.....		43
Figure 3 – Test circuits for a.c. durability and overstressed fault mode.....		44
Figure 4 – Test circuits for impulse durability and overstressed fault mode.....		45
Figure 5 – Test circuits for rated current, series resistance, response time, current reset time, maximum interrupting voltage and operating duty test.....		46
Figure 6 – Test circuits for a.c. durability.....		47
Figure 7 – Test circuits for impulse durability.....		48
Figure 8 – Test circuits for insertion loss.....		49
Figure 9 – Test circuit for return loss.....		49
Figure 10 – Test circuits for longitudinal balance.....		50
Figure 11 – Test circuit for bit error ratio test.....		51
Figure 12 – Test circuit for near-end crosstalk.....		52
Figure 13 – Test circuits for high temperature/humidity endurance and environmental cycling.....		53
Figure 14 – Environmental cycling schedule A with RH ≥ 90 %.....		54
Figure 15 – Environmental cycling B.....		55
Figure A.1 – Configurations of devices with current-limiting component(s) only.....		56
Figure E.1 – Determination of differential mode let-through current.....		60
Figure E.2 – Determination of common mode let-through current.....		61
Figure E.3 – Determination of differential mode let-through current.....		61
Figure E.4 – Determination of differential mode let-through current.....		61
Figure E.5 – Determination of common mode max. let-through current.....		61
Figure E.6 – Determination of common mode max. let-through current at multi-terminal SPDs.....		62

Table 1 – General SPD requirements.....	11
Table 2 – Waveform tolerances.....	19
Table 3 – Voltage and current waveforms for impulse-limiting voltage.....	27
Table 4 – Source voltages and currents for impulse reset test	29
Table 5 – Preferred values of currents for a.c. durability test	30
Table 6 – Test currents for response time.....	32
Table 7 – Preferred values of current for operating duty tests	34
Table 8 – Preferred values of a.c. test currents.....	34
Table 9 – Preferred values of impulse current.....	35
Table 10 – Standard parameters for figure 8.....	35
Table 11 – Impedance values for longitudinal balance test.....	36
Table 12 – Test times for BER test	37
Table 13 – Connectable cross-sectional areas of copper conductors for screw-type terminals or screwless-type terminals	38
Table 14 – Pulling force (screwless terminals)	38
Table 15 – Preferred values of test-time duration for high temperature and humidity endurance.....	41
Table 16 – Preferred values of temperature and duration for environmental cycling tests.....	42

preview generated by EVS

INTERNATIONAL ELECTROTECHNICAL COMMISSION

LOW VOLTAGE SURGE PROTECTIVE DEVICES –**Part 21: Surge protective devices connected to telecommunications
and signalling networks –
Performance requirements and testing methods**

FOREWORD

- 1) The International Electrotechnical Commission (IEC) is a worldwide organization for standardization comprising all national electrotechnical committees (IEC National Committees). The object of IEC is to promote international co-operation on all questions concerning standardization in the electrical and electronic fields. To this end and in addition to other activities, IEC publishes International Standards, Technical Specifications, Technical Reports, Publicly Available Specifications (PAS) and Guides (hereafter referred to as "IEC Publication(s)"). Their preparation is entrusted to technical committees; any IEC National Committee interested in the subject dealt with may participate in this preparatory work. International, governmental and non-governmental organizations liaising with the IEC also participate in this preparation. IEC collaborates closely with the International Organization for Standardization (ISO) in accordance with conditions determined by agreement between the two organizations.
- 2) The formal decisions or agreements of IEC on technical matters express, as nearly as possible, an international consensus of opinion on the relevant subjects since each technical committee has representation from all interested IEC National Committees.
- 3) IEC Publications have the form of recommendations for international use and are accepted by IEC National Committees in that sense. While all reasonable efforts are made to ensure that the technical content of IEC Publications is accurate, IEC cannot be held responsible for the way in which they are used or for any misinterpretation by any end user.
- 4) In order to promote international uniformity, IEC National Committees undertake to apply IEC Publications transparently to the maximum extent possible in their national and regional publications. Any divergence between any IEC Publication and the corresponding national or regional publication shall be clearly indicated in the latter.
- 5) IEC provides no marking procedure to indicate its approval and cannot be rendered responsible for any equipment declared to be in conformity with an IEC Publication.
- 6) All users should ensure that they have the latest edition of this publication.
- 7) No liability shall attach to IEC or its directors, employees, servants or agents including individual experts and members of its technical committees and IEC National Committees for any personal injury, property damage or other damage of any nature whatsoever, whether direct or indirect, or for costs (including legal fees) and expenses arising out of the publication, use of, or reliance upon, this IEC Publication or any other IEC Publications.
- 8) Attention is drawn to the Normative references cited in this publication. Use of the referenced publications is indispensable for the correct application of this publication.
- 9) Attention is drawn to the possibility that some of the elements of this IEC Publication may be the subject of patent rights. IEC shall not be held responsible for identifying any or all such patent rights.

International Standard IEC 61643-21 has been prepared by subcommittee 37A: Low-voltage surge protective devices, of IEC technical committee 37: Surge arresters.

This consolidated version of IEC 61643-21 consists of the first edition (2000) [documents 37A/101/FDIS and 37A/104/RVD], its amendment 1 (2008) [documents 37A/200/FDIS and 37A/201/RVD] and its corrigendum of March 2001.

The technical content is therefore identical to the base edition and its amendment and has been prepared for user convenience.

It bears the edition number 1.1.

A vertical line in the margin shows where the base publication has been modified by amendment 1.

The committee has decided that the contents of the base publication and its amendments will remain unchanged until the maintenance result date indicated on the IEC web site under "<http://webstore.iec.ch>" in the data related to the specific publication. At this date, the publication will be

- reconfirmed,
- withdrawn,
- replaced by a revised edition, or
- amended.

This document is a preview generated by EVS

INTRODUCTION

The purpose of this International Standard is to identify the requirements for Surge Protective Devices (SPDs) used in protecting telecommunication and signalling systems, for example, low-voltage data, voice, and alarm circuits. All of these systems may be exposed to the effects of lightning and power line faults, either through direct contact or induction. These effects may subject the system to overvoltages or overcurrents or both, whose levels are sufficiently high to harm the system. SPDs are intended to provide protection against overvoltages and overcurrents caused by lightning and power line faults. This standard describes tests and requirements which establish methods for testing SPDs and determining their performance.

The SPDs addressed in this International Standard may contain overvoltage protection components only, or a combination of overvoltage and overcurrent protection components. Protection devices containing overcurrent protection components only are not within the coverage of this standard. However, devices with only overcurrent protection components are covered in annex A.

An SPD may comprise several overvoltage and overcurrent protection components. All SPDs are tested on a "black box" basis, i.e., the number of terminals of the SPD determines the testing procedure, not the number of components in the SPD. The SPD configurations are described in 1.2. In the case of multiple line SPDs, each line may be tested independently of the others, but there may also be a need to test all lines simultaneously.

This standard covers a wide range of testing conditions and requirements; the use of some of these is at the discretion of the user. How the requirements of this standard relate to the different types of SPD is described in 1.3. Whilst this is a performance standard and certain capabilities are demanded of the SPDs, failure rates and their interpretation are left to the user. Selection and application principles are covered in IEC 61643-22.

If the SPD is known to be a single component device, it has to meet the requirements of the relevant standard as well as those in this standard.

LOW VOLTAGE SURGE PROTECTIVE DEVICES –

Part 21: Surge protective devices connected to telecommunications and signalling networks – Performance requirements and testing methods

1 General

1.1 Scope

This International Standard is applicable to devices for surge protection of telecommunications and signalling networks against indirect and direct effects of lightning or other transient overvoltages.

The purpose of these SPDs is to protect modern electronic equipment connected to telecommunications and signalling networks with nominal system voltages up to 1 000 V (r.m.s.) a.c. and 1 500 V d.c.

1.2 SPD configurations

The SPD configurations described in this standard are shown in figure 1. Each SPD configuration is composed of one or more voltage-limiting components and may include current-limiting components.

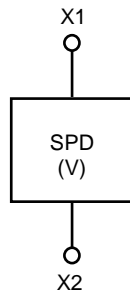

IEC 549/08

Figure 1a – Two-terminal SPD

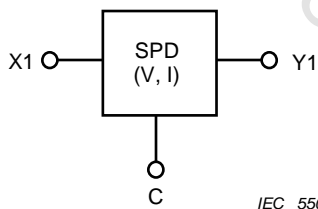

IEC 550/08

Figure 1b – Three-terminal SPD

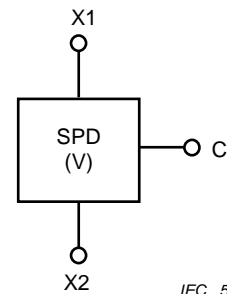

IEC 551/08

Figure 1c – Three-terminal SPD

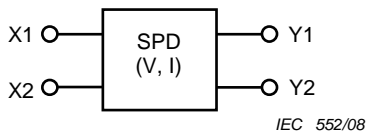

IEC 552/08

Figure 1d – Four-terminal SPD

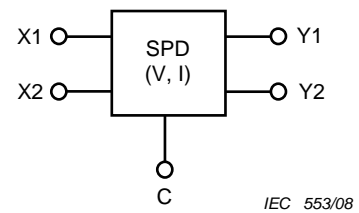

IEC 553/08

Figure 1e – Five-terminal SPD

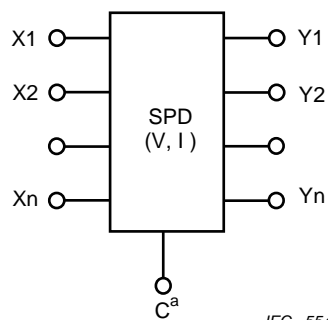

IEC 554/08

Figure 1f – Multi-terminal SPD

^a The common terminal C may not be provided.

Key

- V voltage-limiting component
- V, I voltage-limiting components or a combination of voltage-limiting and current-limiting components
- X1, X2...Xn line terminals
- Y1, Y2...Yn protected line terminals
- C common terminal

Figure 1 – SPD configurations

1.3 Use of this standard

This standard considers two basic types of SPD.

The first type of SPD contains at least one voltage-limiting component and no current-limiting component(s) in a housing. All the SPD configurations of figure 1 can be of this type. These SPDs shall satisfy the requirements of 5.1, 5.2.1 and 5.3 (see table 1). The SPDs shown in figures 1b, 1d, 1e and 1f may contain a linear component between the line terminal and the corresponding protected line terminal. These SPDs shall also satisfy the applicable requirements of 5.2.2.

The second type of SPD contains both voltage-limiting and current-limiting components in a housing. SPD configurations shown in figures 1b, 1d, 1e, and 1f are applicable for SPDs with both voltage-limiting and current-limiting components. This type of SPD shall satisfy the requirements of 5.1, 5.2.1, 5.2.2 and 5.3 (see table 1). Configurations of protective devices having only current-limiting components are covered in annex A.

SPDs may need to satisfy additional requirements depending on the application. The additional requirements are described in 5.2.3 and 5.4 (see table 1).

Subclause 5.2.3 provides transmission tests that SPDs may need to conform to, depending on their communication and signalling application. Selection of the applicable transmission tests from 5.2.3 shall be made, based on the intended application of the SPDs. Table 1 provides general guidance on how to select the applicable transmission tests.

Subclause 5.4 provides the environmental requirements when the SPDs are intended only for use in uncontrolled environments as described in 4.1. SPDs shall satisfy these requirements after an agreement between the user and the manufacturer. Table 1 provides examples of what requirements different types of SPD shall satisfy.

Preview generated by EVS

Table 1 – General SPD requirements

Test series ⁴	Requirement – Test	Sub-clause	Type of SPD					
			SPD with only voltage-limiting function	SPD with both voltage-limiting and current-limiting functions	SPD with voltage-limiting function and linear component between its terminals	SPD having both voltage-limiting and current-limiting functions with enhanced transmission capabilities	SPD having only voltage-limiting function but intended for use in extended range environment	SPD having both voltage-limiting and current-limiting functions but intends for use in extended range environment
1	General test	6.1						
	Identification and documentation	6.1.1	A	A	A	A	A	A
	Marking	6.1.2	A	A	A	A	A	A
	Transmission tests	6.2.3						
	Capacitance	6.2.3.1	A	O	O	O	A	O
	Insertion loss	6.2.3.2	O	A	A	A	O	A
	Return loss	6.2.3.3	O	O	O	A	O	O
	Longitudinal balance	6.2.3.4	O	O	O	A	O	O
	Bit Error Ratio (BER)	6.2.3.5	O	O	O	O	O	O
	Near-end crosstalk (NEXT)	6.2.3.6	O	O	O	A	O	O
	Mechanical tests	6.3						
	Terminals and connectors	6.3.1	A	A	A	A	A	A
	General testing procedure	6.3.1.1	A	A	A	A	A	A
	Terminals with screws	6.3.1.2	A	A	A	A	A	A
	Screwless terminals	6.3.1.3	A	A	A	A	A	A
	Insulating pierced connections	6.3.1.4	A	A	A	A	A	A
	Pull-out-test on SPD terminals designed for single-core conductors	6.3.1.4.1	A	A	A	A	A	A
	Pull-out-test on SPD terminals designed for multi-core cables and cords	6.3.1.4.2	A	A	A	A	A	A
	Mechanical strength (mounting)	6.3.2	A	A	A	A	A	A
	Resistance to ingress of solid objects and to harmful ingress of water	6.3.3	A	A	A	A	A	A
	Protection against direct contact	6.3.4	A	A	A	A	A	A
Fire resistance	6.3.5	A	A	A	A	A	A	

Table 1 (continued)

Test series ⁴	Requirement – Test	Sub-clause	Type of SPD					
			SPD with only voltage-limiting function	SPD with both voltage-limiting and current-limiting functions	SPD with voltage-limiting function and linear component between its terminals	SPD having both voltage-limiting and current-limiting functions with enhanced transmission capabilities	SPD having only voltage-limiting function but intended for use in extended range environment	SPD having both voltage-limiting and current-limiting functions but intended for use in extended range environment
	Environmental tests	6.4						
	High temperature and humidity endurance	6.4.1	O	O	O	O	A	A
	Environmental cycling with impulse surges	6.4.2	O	O	O	O	A	A
	Environmental cycling with a.c. surges	6.4.3	O	O	O	O	A	A
2	Voltage limiting tests	6.2.1						
	Maximum continuous operating voltage (U _c)	6.2.1.1	A	A	A	A	A	A
	Insulation resistance	6.2.1.2	A	A	A	A	A	A
	Impulse durability for voltage limiting function ¹	6.2.1.6	A	A	A	A	A	A
	Impulse-limiting voltage ²	6.2.1.3	A	A	A	A	A	A
	Impulse reset switching types	6.2.1.4	A	A	A	A	A	A
	AC durability for voltage limiting function ¹	6.2.1.5	O	O	O	O	O	O
	Blind spot test multi stage SPD	6.2.1.8	A	A	A	A	A	A
	Overstressed fault mode	6.2.1.7	A	A	A	A	A	A
3	Current limiting tests	6.2.2						
	Rated current	6.2.2.1	N.A.	A	A	A	N.A.	A
	Series resistance	6.2.2.2	N.A.	A	A	A	N.A.	A
	Current response time	6.2.2.3	N.A.	A	N.A.	A ³	N.A.	A ³
	Current reset time	6.2.2.4	N.A.	A	N.A.	A ³	N.A.	A ³
	Maximum interrupting voltage	6.2.2.5	N.A.	A	N.A.	A ³	N.A.	A ³
	Operating duty test	6.2.2.6	N.A.	A	N.A.	A ³	N.A.	A ³
	AC durability for current limiting function ¹	6.2.2.7	N.A.	A	N.A.	A ³	N.A.	A ³
	Impulse durability for current limiting function ¹	6.2.2.8	N.A.	A	N.A.	A ³	N.A.	A ³
4	Acceptance tests	6.5	O	O	O	O	O	O
A	Applicable.							
N.A.	Not applicable.							
O	Optional.							
¹	For each category of test impulse a new set of samples can be used.							
²	It is admissible to measure the impulse-limiting voltage 6.2.1.3 while testing impulse durability 4.2.1.6.							
³	Test not applicable if there is a linear component between its terminals.							
⁴	Each test series is carried out on three samples.							

2 Normative references

The following referenced documents are indispensable for the application of this document. For dated references, only the edition cited applies. For undated references, the latest edition of the referenced document (including any amendments) applies.

IEC 60050(702):1992, *International Electrotechnical Vocabulary – Chapter 702: Oscillations, signals and related devices*

IEC 60050(726):1982, *International Electrotechnical Vocabulary – Chapter 726: Transmission lines and waveguides*

IEC 60060-1:1989, *High-voltage test techniques – Part 1: General definitions and test requirements*

IEC 60068-2-30:1980, *Environmental testing – Part 2: Tests – Test Db and guidance: Damp heat, cyclic (12 + 12-hour cycle)*

IEC 60529, *Degrees of protection provided by enclosures (IP code)*

IEC 60695-2-1/1:1994, *Fire hazard testing – Part 2: Test methods – Section 1/sheet 1: Glow-wire end-product test and guidance*

IEC 60950:1999, *Safety of information technology equipment*

IEC 60999-1:1999, *Connecting devices – Electrical copper conductors – Safety requirements for screw-type and screwless-type clamping units – Part 1: General requirements and particular requirements for clamping units for conductors from 0,2 mm² up to 35 mm² (included)*

IEC 61000-4-5, *Electromagnetic compatibility (EMC) – Part 4: Testing and measurement techniques – Section 5 – Surge immunity test*

IEC 61083-1, *Digital recorders for measurements in high voltage impulse tests – Part 1: Requirements for digital recorders*

IEC 61180-1:1992, *High-voltage test techniques for low-voltage equipment – Part 1: Definitions, test and procedure requirements*

IEC 61643-1, *Surge protective devices connected to low-voltage power distribution systems – Part 1: Performance requirements and testing methods*

IEC 61643-22:2004, *Low-voltage surge protective devices – Part 22: Surge protection devices connected to telecommunications and signalling networks – Selection and application principles*

ITU-T Recommendation K.30:1993, *Positive temperature coefficient (PTC) thermistors*

ITU-T Recommendation K.55:2002, *Overvoltage and overcurrent requirements for insulation displacement connectors (IDC) terminations*

ITU-T Recommendation K.65:2004, *Overvoltage and overcurrent requirements for termination modules with contacts for test ports or SPDs*

ITU-T Recommendation O.9:1999, *Measuring arrangements to assess the degree of unbalance about earth*