

**Jäätmematerjalide või taaskasutatavate osiste
tihendamise masinad. Püstised pallimispressid.
Ohutusnõuded**

**Machines for compacting waste materials or recyclable
fractions - Vertical baling presses - Safety requirements**

EESTI STANDARDI EESSÕNA

NATIONAL FOREWORD

See Eesti standard EVS-EN 16500:2014 sisaldab Euroopa standardi EN 16500:2014 inglisekeelset teksti.	This Estonian standard EVS-EN 16500:2014 consists of the English text of the European standard EN 16500:2014.
Standard on jõustunud sellekohase teate avaldamisega EVS Teatajas.	This standard has been endorsed with a notification published in the official bulletin of the Estonian Centre for Standardisation.
Euroopa standardimisorganisatsioonid on teinud Euroopa standardi rahvuslikele liikmetele kättesaadavaks 06.08.2014.	Date of Availability of the European standard is 06.08.2014.
Standard on kättesaadav Eesti Standardikeskusest.	The standard is available from the Estonian Centre for Standardisation.

Tagasisidet standardi sisu kohta on võimalik edastada, kasutades EVS-i veebilehel asuvat tagasiside vormi või saates e-kirja meiliaadressile standardiosakond@evs.ee.

ICS 13.030.40, 25.120.10

Standardite reprodutseerimise ja levitamise õigus kuulub Eesti Standardikeskusele

Andmete paljundamine, taastekitamine, kopeerimine, salvestamine elektroonsesse süsteemi või edastamine ükskõik millises vormis või millisel teel ilma Eesti Standardikeskuse kirjaliku loata on keelatud.

Kui Teil on küsimusi standardite autorikaitse kohta, võtke palun ühendust Eesti Standardikeskusega:
Aru 10, 10317 Tallinn, Eesti; www.evs.ee; telefon 605 5050; e-post info@evs.ee

The right to reproduce and distribute standards belongs to the Estonian Centre for Standardisation

No part of this publication may be reproduced or utilized in any form or by any means, electronic or mechanical, including photocopying, without a written permission from the Estonian Centre for Standardisation.

If you have any questions about copyright, please contact Estonian Centre for Standardisation:
Aru 10, 10317 Tallinn, Estonia; www.evs.ee; phone 605 5050; e-mail info@evs.ee

ICS 13.030.40; 25.120.10

English Version

Machines for compacting waste materials or recyclable fractions - Vertical baling presses - Safety requirements

Machines de compactage pour déchets ou matières
recyclables - Presses à balles verticales - Prescriptions de
sécurité

Maschinen zum Verdichten von Abfällen oder recyclebaren
Materialien - Vertikale Ballenpressen -
Sicherheitsanforderungen

This European Standard was approved by CEN on 14 June 2014.

CEN members are bound to comply with the CEN/CENELEC Internal Regulations which stipulate the conditions for giving this European Standard the status of a national standard without any alteration. Up-to-date lists and bibliographical references concerning such national standards may be obtained on application to the CEN-CENELEC Management Centre or to any CEN member.

This European Standard exists in three official versions (English, French, German). A version in any other language made by translation under the responsibility of a CEN member into its own language and notified to the CEN-CENELEC Management Centre has the same status as the official versions.

CEN members are the national standards bodies of Austria, Belgium, Bulgaria, Croatia, Cyprus, Czech Republic, Denmark, Estonia, Finland, Former Yugoslav Republic of Macedonia, France, Germany, Greece, Hungary, Iceland, Ireland, Italy, Latvia, Lithuania, Luxembourg, Malta, Netherlands, Norway, Poland, Portugal, Romania, Slovakia, Slovenia, Spain, Sweden, Switzerland, Turkey and United Kingdom.



EUROPEAN COMMITTEE FOR STANDARDIZATION
COMITÉ EUROPÉEN DE NORMALISATION
EUROPÄISCHES KOMITEE FÜR NORMUNG

CEN-CENELEC Management Centre: Avenue Marnix 17, B-1000 Brussels

Contents

Page

Foreword.....	4
Introduction.....	5
1 Scope.....	6
2 Normative references.....	7
3 Terms and definitions.....	9
4 List of significant hazards.....	13
5 Safety requirements and/or protective measures.....	16
5.1 Mechanical hazards.....	16
5.1.1 General.....	16
5.1.2 Feed area.....	19
5.1.3 Baling chamber area.....	22
5.1.4 Bale ejection area.....	22
5.2 Control actuators, devices and system.....	23
5.2.1 Control actuators and devices.....	23
5.2.2 Required performance levels PL _r	24
5.2.3 Prevention of unauthorised or unintentional operation or start-up.....	25
5.2.4 Emergency stop.....	25
5.3 Hazards from hydraulic equipment.....	26
5.3.1 Hydraulic equipment.....	26
5.3.2 Hot surfaces of the hydraulic system.....	26
5.3.3 Hydraulic control system.....	26
5.4 Hazards from pneumatic equipment.....	26
5.4.1 Pneumatic equipment.....	26
5.4.2 Pneumatic control system.....	27
5.5 Electrical hazards.....	27
5.6 Hazards generated by noise.....	27
5.6.1 Noise reduction at source by design.....	27
5.6.2 Noise reduction by protective measures.....	28
5.6.3 Information connected with noise hazards.....	28
5.7 Hazards due to neglecting ergonomic principles in the design of the machine.....	28
6 Verification of the safety requirements and/or protective measures.....	28
7 Information for use.....	30
7.1 General information.....	30
7.2 Information for safe operation.....	30
7.2.1 General.....	30
7.2.2 Instructions for operation.....	31
7.2.3 Instructions for maintenance.....	31
7.2.4 Instructions for periodic examinations.....	32
7.2.5 Information on installation.....	32
7.2.6 Information on noise.....	33
7.3 Marking.....	33
7.3.1 Manufacturer's marking plate.....	33
7.3.2 Safety signs.....	33
7.3.3 Other markings.....	34
Annex A (normative) Noise test code.....	35
A.1 Scope.....	35
A.2 Determination of emission sound pressure level at the work station(s).....	35
A.2.1 Basic standards.....	35

A.2.2	Measurement uncertainty	36
A.3	Determination of sound power levels	36
A.3.1	Basic standards	36
A.3.2	Measurement uncertainty	36
A.4	Installation and mounting conditions for the noise measurement	36
A.5	Operating conditions	36
A.6	Information to be recorded and reported.....	37
A.6.1	General	37
A.6.2	Vertical baling press – Data.....	37
A.6.3	Standards used.....	37
A.6.4	Noise data.....	37
A.6.5	Specified test parameters.....	37
A.6.6	Installation and operating conditions	37
A.7	Declaration and verification of noise emission values	37
Annex ZA (informative)	Relationship between this European Standard and the Essential Requirements of EU Directive 2006/42/EC.....	39
Bibliography.....		40

Foreword

This document (EN 16500:2014) has been prepared by Technical Committee CEN/TC 397 "Project Committee - Baling presses - Safety requirements", the secretariat of which is held by DIN.

This European Standard shall be given the status of a national standard, either by publication of an identical text or by endorsement, at the latest by February 2015 and conflicting national standards shall be withdrawn at the latest by February 2015.

Attention is drawn to the possibility that some of the elements of this document may be the subject of patent rights. CEN [and/or CENELEC] shall not be held responsible for identifying any or all such patent rights.

This document has been prepared under a mandate given to CEN by the European Commission and the European Free Trade Association, and supports essential requirements of EU Directive(s).

For relationship with EU Directive(s), see informative Annex ZA, which is an integral part of this document.

According to the CEN-CENELEC Internal Regulations, the national standards organizations of the following countries are bound to implement this European Standard: Austria, Belgium, Bulgaria, Croatia, Cyprus, Czech Republic, Denmark, Estonia, Finland, Former Yugoslav Republic of Macedonia, France, Germany, Greece, Hungary, Iceland, Ireland, Italy, Latvia, Lithuania, Luxembourg, Malta, Netherlands, Norway, Poland, Portugal, Romania, Slovakia, Slovenia, Spain, Sweden, Switzerland, Turkey and the United Kingdom.

Introduction

This European Standard is a type C standard as stated in EN ISO 12100.

The machinery concerned and the extent to which hazards, hazardous situations and hazardous events are covered are indicated in the scope of this document.

When provisions of this type C standard are different from those which are stated in type A or B standards, the provisions of this type C standard take precedence over the provisions of the other standards for machines that have been designed and built in accordance with the provisions of this type C standard.

This document is a preview generated by EVS

1 Scope

This European Standard specifies the safety requirements for the design, manufacture and information for safe use of vertical baling presses for compacting waste material or recyclable fractions (e. g. paper, plastics, textiles, cans, cardboard, mixed waste), hereafter referred to as materials.

This standard covers vertical baling presses:

- that are manually or mechanically fed; and
- with fixed enclosed baling chambers (single or multiple chamber presses); and
- with a mechanically, hydraulically or pneumatically operated compacting equipment; and
- where the compacted bale is tied manually in the baling chamber; and
- with manual unloading or mechanical ejection of the compacted bale.

The scope of this standard includes any mechanical feed equipment, such as belt type conveyors or bin lifts, forming an integral part of the baling press assembly. It also includes integral material flow control equipment.

This standard does not apply to:

- vertical baling presses without fixed enclosed baling chamber(s); or
- round balers or roll baling machines; or
- machines where the material is compacted into a bag; or
- pneumatic conveying systems; or
- equipment for transporting the bales; or
- local exhaust ventilation for the removal of dusts or vapours; or
- hazards arising from any integral pre-conditioning equipment; or
- hazards arising from the materials being processed (e.g. asbestos, clinical waste, flammable or explosive materials, unhealthy or poisonous waste).

This standard does not apply to cranes, lift trucks or other mobile plant used to load materials into the feed opening. Nor does it apply to hazards arising from loading materials into the feed opening using cranes, lift trucks or other mobile plant.

This standard does not include specifications to meet the requirements of the ATEX Directive 94/9/EC.

All hazards mentioned in Clause 4 are dealt with in this European Standard.

This European Standard is not applicable for vertical baling presses which are manufactured before the date of its publication as an EN.

2 Normative references

The following documents, in whole or in part, are normatively referenced in this document and are indispensable for its application. For dated references, only the edition cited applies. For undated references, the latest edition of the referenced document (including any amendments) applies.

EN 349:1993+A1:2008, *Safety of machinery - Minimum gaps to avoid crushing of parts of the human body*

EN 574:1996+A1:2008, *Safety of machinery - Two-hand control devices - Functional aspects - Principles for design*

EN 620:2002+A1:2010, *Continuous handling equipment and systems - Safety and EMC requirements for fixed belt conveyors for bulk materials*

EN 953:1997+A1:2009, *Safety of machinery - Guards - General requirements for the design and construction of fixed and movable guards*

EN 1005-1:2001+A1:2008, *Safety of machinery - Human physical performance - Part 1: Terms and definitions*

EN 1005-2:2003+A1:2008, *Safety of machinery - Human physical performance - Part 2: Manual handling of machinery and component parts of machinery*

EN 1005-3:2002+A1:2008, *Safety of machinery - Human physical performance - Part 3: Recommended force limits for machinery operation*

EN 1005-4:2005+A1:2008, *Safety of machinery - Human physical performance - Part 4: Evaluation of working postures and movements in relation to machinery*

EN 1037:1995+A1:2008, *Safety of machinery - Prevention of unexpected start-up*

EN 60204-1:2006, *Safety of machinery - Electrical equipment of machines - Part 1: General requirements (IEC 60204-1:2005, modified)*

EN 60529:1991, *Degrees of protection provided by enclosures (IP Code) (IEC 60529:1989)*

EN 61496-1:2004, *Safety of machinery - Electro-sensitive protective equipment - Part 1: General requirements and tests (IEC 61496-1:2004, modified)*

CLC/TS 61496-2:2006, *Safety of machinery - Electro-sensitive protective equipment - Part 2: Particular requirements for active opto-electronic protective devices (AOPDs) (IEC 61496-2:2006)*

CLC/TS 61496-3:2008, *Safety of machinery - Electro-sensitive protective equipment - Part 3: Particular requirements for active opto-electronic protective devices responsive to diffuse reflection (AOPDDR) (IEC 61496-3:2008)*

EN 62262:2002, *Degrees of protection provided by enclosures for electrical equipment against external mechanical impacts (IK code) (IEC 62262:2002)*

EN 82079-1:2012, *Preparation of instructions for use - Structuring, content and presentation - Part 1: General principles and detailed requirements (IEC 82079-1:2012)*

EN ISO 3744:2010, *Acoustics - Determination of sound power levels and sound energy levels of noise sources using sound pressure - Engineering methods for an essentially free field over a reflecting plane (ISO 3744:2010)*

EN ISO 3746:2010, *Acoustics - Determination of sound power levels and sound energy levels of noise sources using sound pressure - Survey method using an enveloping measurement surface over a reflecting plane (ISO 3746:2010)*

EN ISO 3747:2010, *Acoustics - Determination of sound power levels and sound energy levels of noise sources using sound pressure - Engineering/survey methods for use in situ in a reverberant environment (ISO 3747:2010)*

EN ISO 4413:2010, *Hydraulic fluid power - General rules and safety requirements for systems and their components (ISO 4413:2010)*

EN ISO 4414:2010, *Pneumatic fluid power - General rules and safety requirements for systems and their components (ISO 4414:2010)*

EN ISO 4871:2009, *Acoustics - Declaration and verification of noise emission values of machinery and equipment (ISO 4871:1996)*

EN ISO 9614-2:1996, *Acoustics - Determination of sound power levels of noise sources using sound intensity - Part 2: Measurement by scanning (ISO 9614-2:1996)*

EN ISO 11201:2010, *Acoustics - Noise emitted by machinery and equipment - Determination of emission sound pressure levels at a work station and at other specified positions in an essentially free field over a reflecting plane with negligible environmental corrections (ISO 11201:2010)*

EN ISO 11202:2010, *Acoustics - Noise emitted by machinery and equipment - Determination of emission sound pressure levels at a work station and at other specified positions applying approximate environmental corrections (ISO 11202:2010)*

EN ISO 11204:2010, *Acoustics - Noise emitted by machinery and equipment - Determination of emission sound pressure levels at a work station and at other specified positions applying accurate environmental corrections (ISO 11204:2010)*

EN ISO 12100:2010, *Safety of machinery - General principles for design - Risk assessment and risk reduction (ISO 12100:2010)*

EN ISO 13732-1:2008, *Ergonomics of the thermal environment - Methods for the assessment of human responses to contact with surfaces - Part 1: Hot surfaces (ISO 13732-1:2006)*

EN ISO 13849-1:2008, *Safety of machinery - Safety-related parts of control systems - Part 1: General principles for design (ISO 13849-1:2006)*

EN ISO 13850:2008, *Safety of machinery - Emergency stop - Principles for design (ISO 13850:2006)*

EN ISO 13855:2010, *Safety of machinery - Positioning of safeguards with respect to the approach speeds of parts of the human body (ISO 13855:2010)*

EN ISO 13856-2:2013, *Safety of machinery - Pressure-sensitive protective devices - Part 2: General principles for design and testing of pressure-sensitive edges and pressure-sensitive bars (ISO 13856-2:2013)*

EN ISO 13856-3:2013, *Safety of machinery - Pressure-sensitive protective devices - Part 3: General principles for design and testing of pressure-sensitive bumpers, plates, wires and similar devices (ISO 13856-3:2013)*

EN ISO 13857:2008, *Safety of machinery - Safety distances to prevent hazard zones being reached by upper and lower limbs (ISO 13857:2008)*

EN ISO 14119:2013, *Safety of machinery - Interlocking devices associated with guards - Principles for design and selection (ISO 14119:2013)*

EN ISO 14122-1:2001, *Safety of machinery - Permanent means of access to machinery - Part 1: Choice of fixed means of access between two levels (ISO 14122-1:2001)*

EN ISO 14122-2:2001, *Safety of machinery - Permanent means of access to machinery - Part 2: Working platforms and walkways (ISO 14122-2:2001)*

EN ISO 14122-3:2001, *Safety of machinery - Permanent means of access to machinery - Part 3: Stairs, stepladders and guard-rails (ISO 14122-3:2001)*

EN ISO 14122-4:2004, *Safety of machinery - Permanent means of access to machinery - Part 4: Fixed ladders (ISO 14122-4:2004)*

3 Terms and definitions

For the purposes of this document, the terms and definitions given in EN ISO 12100:2010 and the following apply.

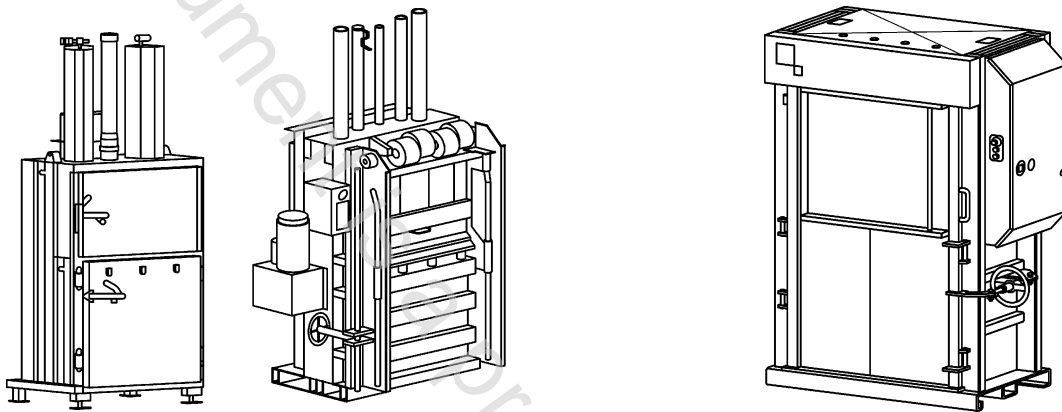

a) Front/ side -loaded single chamber baling presses with fixed position compacting head

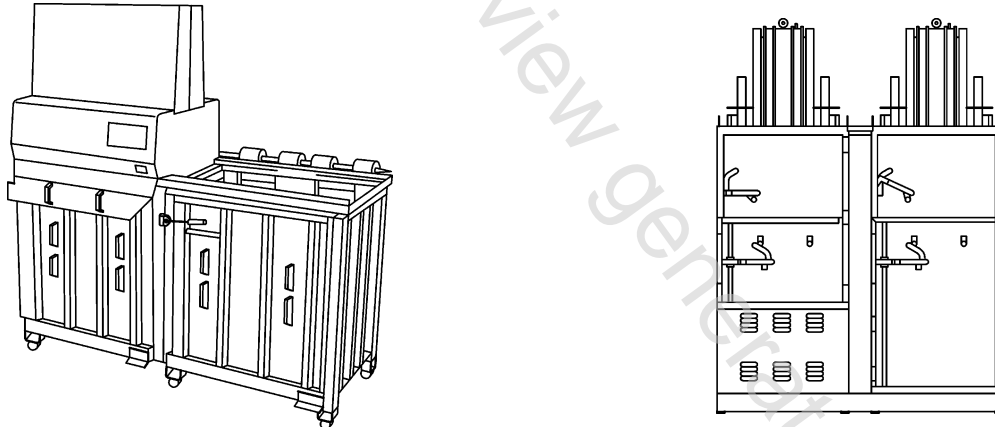

b) Top-loaded multi chamber baling press with moveable position compacting head

c) Front-loaded multi chamber baling press with fixed position compacting head

Figure 1 — Examples of vertical baling presses