

---

---

**Stationary training equipment —**

Part 7:

**Rowing machines, additional specific  
safety requirements and test method**

*Équipement d'entraînement fixe —*

*Partie 7: Rameurs — Exigences spécifiques de sécurité et méthodes  
d'essai supplémentaires*



**PDF disclaimer**

This PDF file may contain embedded typefaces. In accordance with Adobe's licensing policy, this file may be printed or viewed but shall not be edited unless the typefaces which are embedded are licensed to and installed on the computer performing the editing. In downloading this file, parties accept therein the responsibility of not infringing Adobe's licensing policy. The ISO Central Secretariat accepts no liability in this area.

Adobe is a trademark of Adobe Systems Incorporated.

Details of the software products used to create this PDF file can be found in the General Info relative to the file; the PDF-creation parameters were optimized for printing. Every care has been taken to ensure that the file is suitable for use by ISO member bodies. In the unlikely event that a problem relating to it is found, please inform the Central Secretariat at the address given below.

This document is a preview generated by EVS

© ISO 2005

All rights reserved. Unless otherwise specified, no part of this publication may be reproduced or utilized in any form or by any means, electronic or mechanical, including photocopying and microfilm, without permission in writing from either ISO at the address below or ISO's member body in the country of the requester.

ISO copyright office  
Case postale 56 • CH-1211 Geneva 20  
Tel. + 41 22 749 01 11  
Fax + 41 22 749 09 47  
E-mail [copyright@iso.org](mailto:copyright@iso.org)  
Web [www.iso.org](http://www.iso.org)

Published in Switzerland

## Foreword

ISO (the International Organization for Standardization) is a worldwide federation of national standards bodies (ISO member bodies). The work of preparing International Standards is normally carried out through ISO technical committees. Each member body interested in a subject for which a technical committee has been established has the right to be represented on that committee. International organizations, governmental and non-governmental, in liaison with ISO, also take part in the work. ISO collaborates closely with the International Electrotechnical Commission (IEC) on all matters of electrotechnical standardization.

International Standards are drafted in accordance with the rules given in the ISO/IEC Directives, Part 2.

The main task of technical committees is to prepare International Standards. Draft International Standards adopted by the technical committees are circulated to the member bodies for voting. Publication as an International Standard requires approval by at least 75 % of the member bodies casting a vote.

Attention is drawn to the possibility that some of the elements of this document may be the subject of patent rights. ISO shall not be held responsible for identifying any or all such patent rights.

ISO 20957-7 was prepared by CEN (as EN 957-7) and was adopted, under a special “fast-track procedure”, by Technical Committee ISO/TC 83, *Sports and recreational equipment*, in parallel with its approval by the ISO member bodies.

ISO 20957 consists of the following parts, under the general title *Stationary training equipment*:

- *Part 1: General safety requirements and test methods*
- *Part 2: Strength training equipment, additional specific safety requirements and test methods*
- *Part 4: Strength training benches, additional specific safety requirements and test methods*
- *Part 5: Pedal crank training equipment, additional specific safety requirements and test methods*
- *Part 6: Treadmills, additional specific safety requirements and test methods*
- *Part 7: Rowing machines, additional specific safety requirements and test methods*
- *Part 8: Steppers, stairclimbers and climbers — Additional specific safety requirements and test methods*
- *Part 9: Elliptical trainers, additional specific safety requirements and test methods*

## Contents

Foreword .....	3
Introduction .....	3
1 Scope.....	4
2 Normative references .....	4
3 Definitions.....	4
4 Classification.....	6
5 Safety requirements.....	6
6 Test methods.....	8
7 Additional instructions for use.....	12

This document is a preview generated by EVS

## Foreword

This European Standard has been prepared by Technical Committee CEN/TC 136 "Sports, playground and other recreational equipment", the secretariat of which is held by DIN.

This European Standard shall be given the status of a national standard, either by publication of an identical text or by endorsement, at the latest by December 1998, and conflicting national standards shall be withdrawn at the latest by December 1998.

This standard EN 957 "Stationary training equipment" consists of the following parts:

*Part 1: General safety requirements and test methods*

*Part 2: Strength training equipment, additional specific safety requirements and test methods*

*Part 4: Strength training benches, additional specific safety requirements and test methods*

*Part 5: Pedal crank training equipment, additional specific safety requirements and test methods*

*Part 6: Tread mills, additional specific safety requirements and test methods*

*Part 7: Rowing machines, additional specific safety requirements and test methods*

*Part 8: Steppers, stairclimbers and climbers, additional specific safety requirements and test methods*

According to the CEN/CENELEC Internal Regulations, the national standards organizations of the following countries are bound to implement this European Standard: Austria, Belgium, Czech Republic, Denmark, Finland, France, Germany, Greece, Iceland, Ireland, Italy, Luxembourg, Netherlands, Norway, Portugal, Spain, Sweden, Switzerland and the United Kingdom.

## Introduction

This part of EN 957 concerns the safety of rowing machines.

It amends and supplements EN 957-1. The requirements of this specific standard take priority over those in the general standard.

This document is a preview generated by EVS

## 1 Scope

This part of EN 957 specifies safety requirements for rowing machines in addition to the general safety requirements of EN 957-1 and should be read in conjunction with it.

This part of EN 957 is applicable to stationary training equipment type rowing machines (type 7), hereinafter referred to as rowing machines, within the classes S and H and class A regarding accuracy.

If accessories are provided with the rowing machine for the performance of additional exercises these are subject to the requirements of EN 957-1 and any other specific requirements of the appropriate part of this standard.

## 2 Normative references

This European Standard incorporates by dated or undated reference, provisions from other publications. These normative references are cited at the appropriate places in the text and the publications are listed hereafter. For dated references, subsequent amendments to or revisions of any of these publications apply to this European Standard only when incorporated in it by amendment or revision. For undated references the latest edition of the publication referred to applies.

EN 71-1, *Safety of toys — Mechanical and physical properties.*

EN 547-3, *Safety of machinery — Human body measurements — Part 3: Anthropometric data.*

EN 957-1:1996, *Stationary training equipment — Part 1: General safety requirements and test methods.*

## 3 Definitions

For the purposes of this standard the definitions of EN 957-1 and the following apply:

### **rowing machine**

stationary training equipment with a moving seat simulating a motion like rowing (see figures 1 to 3).

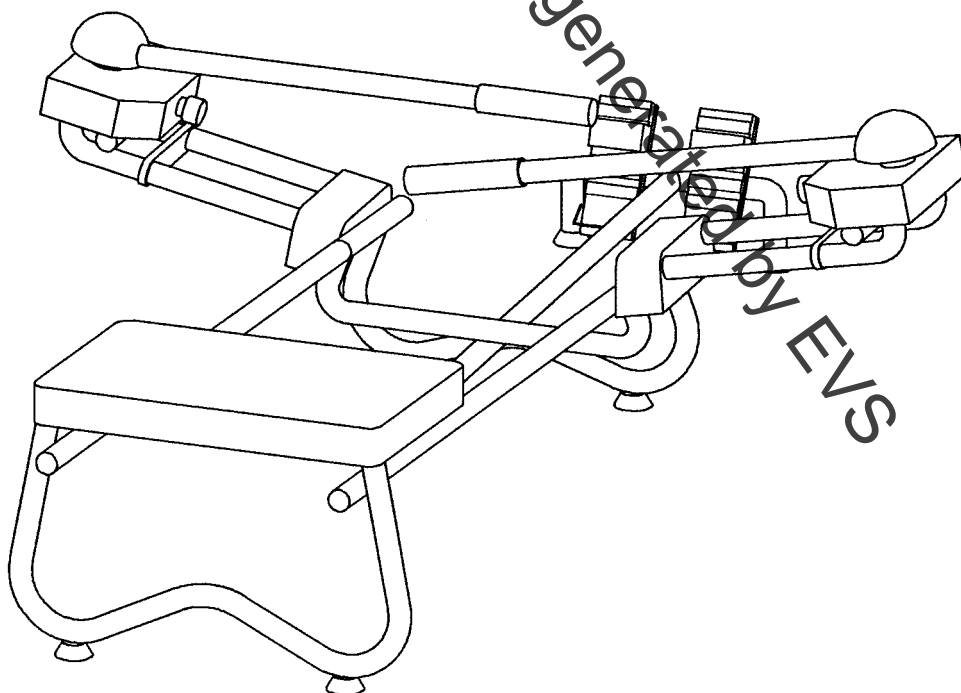

Figure 1 — Example of a rowing machine with sculling system