

ISO

INTERNATIONAL ORGANIZATION FOR STANDARDIZATION

110

ISO RECOMMENDATION R 1214

COUNTERBALANCED FORK LIFT TRUCKS

RATED CAPACITY

1st EDITION

July 1971

COPYRIGHT RESERVED

The copyright of ISO Recommendations and ISO Standards belongs to ISO Member Bodies. Reproduction of these documents, in any country, may be authorized therefore only by the national standards organization of that country, being a member of ISO.

For each individual country the only valid standard is the national standard of that country.

Printed in Switzerland

Also issued in French and Russian. Copies to be obtained through the national standards organizations.

BRIEF HISTORY

The ISO Recommendation R 1214, *Counterbalanced fork lift trucks – Rated capacity*, was drawn up by Technical Committee ISO/TC 110, *Industrial trucks*, the Secretariat of which is held by the Association Française de Normalisation (AFNOR).

Work on this question led to the adoption of Draft ISO Recommendation No. 1063, which was circulated to all the ISO Member Bodies for enquiry in February 1970. It was approved, subject to a few modifications of an editorial nature, by the following Member Bodies :

Brazil	Ireland	Spain
Bulgaria	Israel	Switzerland
Czechoslovakia	Italy	Thailand
France	Japan	U.A.R.
Germany	New Zealand	United Kingdom
Greece	Poland	U.S.S.R.
India	South Africa, Rep. of	Yugoslavia

The following Member Bodies opposed the approval of the Draft :

Australia
Belgium
Sweden
U.S.A.

This Draft ISO Recommendation was then submitted by correspondence to the ISO Council, which decided to accept it as an ISO RECOMMENDATION.

COUNTERBALANCED FORK LIFT TRUCKS

RATED CAPACITY

1. SCOPE

This ISO Recommendation defines, for counterbalanced fork lift trucks, when equipped with load carrying forks, the manufacturer's rated capacity, and fixes their conditions of design, the standard load centre distances, the stability requirements and the rules of marking.

2. DEFINITION

The manufacturer's rated capacity of a fork lift truck should correspond to the maximum load Q which the truck, with vertical mast, can carry at the distance D (load centre distance) appropriate for the foreseen use of the truck, and measured between the centre of gravity G of the load and

- (a) the front face of the fork shank;
- (b) the upper face of the fork blade (see Figure).

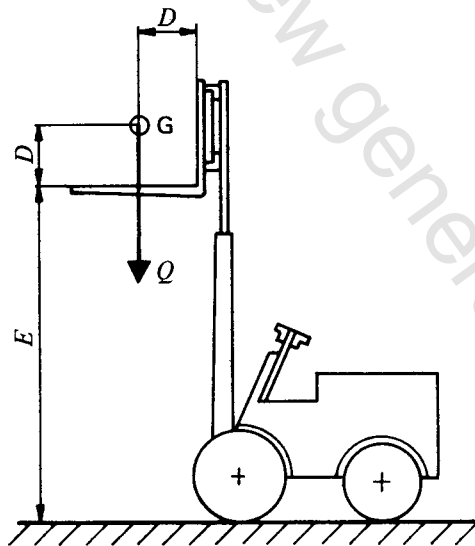

- D = Load centre distance
- E = Lift height
- G = Centre of gravity, located in the longitudinal plane of symmetry of the truck
- Q = Load

FIGURE